



Cased/Uncased Coils For Gas and Oil Furnaces



TCFZ

featuring Industry Standard R-410A
Refrigerant
Airflow Capacity
600-1,900 CFM [283-897 L/s]

Manufactured for
Thermal Zone™
Philadelphia, PA

Table of Contents

Features & Benefits	3
Model Number Identification	4
Coil Specifications.....	5-6
Coil Dimensions and Weights	7
Accessories	8-9
Limited Warranty.....	12

Features & Benefits

- Thermal Zone™ Indoor Furnace cased coils and replacement uncased coils are designed for use with Thermal Zone outdoor units and are available for vertical upflow or downflow, and horizontal left or horizontal right airflow. When matched with Thermal Zone outdoor units, the coils provide a nominal capacity range from 18,000 BTU/HR [5.24 kW] to 60,000 BTU/HR [17.6 kW].
- Constructed of aluminum fins bonded to internally grooved aluminum tubing.
- Coils are tested at the factory with an extensive refrigerant leak check.
- Coils have copper sweat refrigerant connections.
- Feature two sets of 3/4" [14.1 mm] N.P.T. Condensate drain connections for ease of connection.
- Chatleff metering device connections, at inlet and outlet of TXV or EEV and equalizer connections (TXV only).
- Approved for system application with variety of Thermal Zone outdoor units.
- Condensate drain pan is constructed of high grade, heat resistant, corrosion free thermal-set material.
- Compatible with Germicidal Light System (UV resistant).
- Bi-Directional airflow eliminates the need to switch any internal components from horizontal left to right.
- Unique drain pan design maximizes application flexibility and condensate removal.
- N-Coil design maximizes performance and minimizes height required at installation.
- Coils are AHRI certified for system application with a variety of Thermal Zone outdoor units.

Model Number Identification

<u>T</u>	<u>C</u>	<u>F</u>	<u>Z</u>	<u>24</u>	<u>14</u>	<u>S</u>	<u>T</u>	<u>A</u>	<u>A</u>	<u>M</u>	<u>C</u>	<u>*</u>
Brand	Product Category	Type	Refrigerant	Capacity	Width	Efficiency	Metering Device	Major Series	Coil Series	Orientation	Casing	Option Code
Thermal Zone	C= Coil	F = Furnace Coil	Z = R410A	24 = 24,000 BTU/H 30 = 30,000 BTU/H 36 = 36,000 BTU/H 42 = 42,000 BTU/H 48 = 48,000 BTU/H 60 = 60,000 BTU/H	14 = 14" 17 = 17.5" 21 = 21" 24 = 24.5"	S = Standard M = Medium H = High U = Ultra	T = TXV E = EXV	A = First	A = A-Coil N = N-Coil	M = Multipoise V = Vertical only/ Convertible	C = Cased	*

TXV MODELS AVAILABLE
TCFZ2414STAAMC
TCFZ2417MTANMC
TCFZ2417STANMC
TCFZ2421MTANMC
TCFZ3617STANMC
TCFZ3621MTAAMC
TCFZ3621MTANMC
TCFZ3621STANMC
TCFZ3624MTANMC
TCFZ4821STAAMC
TCFZ4821STANMC
TCFZ4824MTANMC
TCFZ4824STANMC
TCFZ6021STAAMC
TCFZ6024STANMC

EEV MODELS AVAILABLE
TCFZ2417SEANMC
TCFZ2421HEAAMC
TCFZ3617SEANMC
TCFZ3621MEAAMC
TCFZ3621SEANMC
TCFZ4821SEAAMC
TCFZ4821SEANMC
TCFZ4824SEANMC
TCFZ6021SEAAMC
TCFZ6024SEANMC
TCFZ3621MEANMC
TCFZ2421MEANMC
TCFZ2421HEANMC

Table 1: Coil Specifications/Airflow Pressure Drop

Coil Model (-)CF	Approx. Design Cooling Air Flow Range CFM [L/s]	Face Area Sq. Ft. [m ²]	Fins Per Inch / Rows Deep	Width	Nominal Capacity	Wet Coil Static Pressure Drop (Inches W.C.) [kPa] @ CFM [L/s] – (Coil Only)													
						600 [283]	700 [330]	800 [378]	900 [425]	1000 [472]	1100 [519]	1200 [566]	1300 [614]	1400 [661]	1500 [708]	1600 [755]	1700 [802]	1800 [850]	1900 [897]
TCFZ2414STAAMC	600/900 [283/425]	4.56 [0.42]	16/2	14	1.5 – 2	0.165	0.209	0.262	0.325	—	—	—	—	—	—	—	—	—	
TCFZ2417STANMC TCFZ2417SEANMC	600/900 [283/425]	4.56 [0.42]	16/2			0.120	0.157	0.199	0.246	—	—	—	—	—	—	—	—	—	—
TCFZ2417MTANMC	600/900 [283/425]	5.70 [0.52]	16/2			0.113	0.145	0.181	0.222	—	—	—	—	—	—	—	—	—	—
TCFZ3617STANMC TCFZ3617SEANMC	700/1300 [330/614]	5.70 [0.52]	16/2		2.5 – 3	0.113	0.145	0.181	0.222	0.266	0.315	0.368	—	—	—	—	—	—	—
TCFZ2421MTANMC TCFZ2421MEANMC	600/900 [283/425]	5.70 [0.52]	16/2			0.113	0.145	0.181	0.222	—	—	—	—	—	—	—	—	—	—
TCFZ3621STANMC TCFZ3621SEANMC	700/1300 [330/614]	5.70 [0.52]	16/2		2.5 – 3	0.113	0.145	0.181	0.222	0.266	0.315	0.368	—	—	—	—	—	—	—
TCFZ3621MTANMC TCFZ3621MEANMC	700/1300 [330/614]	8.55 [0.79]	16/2			0.062	0.086	0.112	0.140	0.170	0.202	0.236	—	—	—	—	—	—	—
TCFZ3621MTAAMC	700/1300 [330/614]	7.60 [0.70]	13/3			0.106	0.125	0.146	0.169	0.194	0.221	0.251	—	—	—	—	—	—	—
TCFZ4821STAAMC	1100/1800 [519/850]	7.60 [0.70]	13/3		3.5 – 4	0.106	0.125	0.146	0.169	0.194	0.221	0.251	0.282	0.315	0.350	0.386	0.425	0.466	—
TCFZ4821STANMC	1100/1800 [519/850]	8.55 [0.79]	16/2			0.062	0.086	0.112	0.140	0.170	0.202	0.236	0.272	0.309	0.349	0.391	0.434	0.480	0.527
TCFZ4821STANMC TCFZ3621MEAAMC TCFZ6021STAAMC TCFZ2421HEAAMC	1400/1600 [661/755]	7.60 [0.70]	13/3		2 – 5	0.036	0.050	0.065	0.081	0.098	0.117	0.137	0.158	0.180	0.203	0.228	0.254	—	—
TCFZ3624MTANMC	700/1300 [330/614]	8.55 [0.79]	16/2			0.062	0.086	0.112	0.140	0.170	0.202	0.236	0.272	0.309	—	—	—	—	—
TCFZ4824STANMC	1100/1800 [519/850]	8.55 [0.79]	16/2		3.5 – 4	0.062	0.086	0.112	0.140	0.170	0.202	0.236	0.272	0.309	0.349	0.391	0.434	0.480	—
TCFZ4824MTANMC	1100/1800 [519/850]	9.98 [0.93]	14/3			0.036	0.050	0.065	0.081	0.098	0.117	0.137	0.158	0.180	0.203	0.228	0.254	0.281	—
TCFZ6024STANMC TCFZ4824SEANMC	1400/1800 [661/755]	9.98 [0.93]	14/3	5	0.036	0.050	0.065	0.081	0.098	0.117	0.137	0.158	0.180	0.203	0.228	0.254	0.281	—	

[] Designates Metric Conversions

Table 1: Coil Specifications/Airflow Pressure Drop (con't.)

Coil Model (-)CF	Approx. Design Cooling Air Flow Range CFM [L/s]	Face Area Sq. Ft. [m ²]	Fins Per Inch / Rows Deep	Width	Nominal Capacity	Wet Coil Static Pressure Drop (Inches W.C.) [kPa] @ CFM [L/s] – (Coil Only)													
						600 [283]	700 [330]	800 [378]	900 [425]	1000 [472]	1100 [519]	1200 [566]	1300 [614]	1400 [661]	1500 [708]	1600 [755]	1700 [802]	1800 [850]	1900 [897]
TCFZ2414STAAMC	600/1600 [283/755]	4.56 [0.42]	16/2	14	1.5 – 2	0.118	0.118	0.145	0.176	0.210	0.247	0.288	0.332	0.379	0.429	0.483	—	—	—
TCFZ2417STANMC TCFZ2417SEANMC	600/1500 [283/707]	4.56 [0.42]	16/2			0.116	0.116	0.151	0.190	0.235	0.284	0.338	0.397	0.461	0.530	—	—	—	—
TCFZ2417MTANMC	600/1600 [283/755]	5.7 [0.52]	16/2			0.101	0.101	0.129	0.161	0.196	0.235	0.277	0.323	0.373	0.425	0.482	—	—	—
TCFZ3617STANMC TCFZ3617SEANMC	600/1600 [283/755]	5.7 [0.52]	16/2		2.5 – 3	0.101	0.101	0.129	0.161	0.196	0.235	0.277	0.323	0.373	0.425	0.482	—	—	—
TCFZ2421MTANMC	600/1600 [283/755]	5.7 [0.52]	16/2			0.101	0.101	0.129	0.161	0.196	0.235	0.277	0.323	0.373	0.425	0.482	—	—	—
TCFZ2421MEANMC	600/1600 [283/755]	5.7 [0.52]	16/2			0.101	0.101	0.129	0.161	0.196	0.235	0.277	0.323	0.373	0.425	0.482	—	—	—
TCFZ3621STANMC TCFZ3621SEANMC	600/1600 [283/755]	5.7 [0.52]	16/2		2.5 – 3	0.101	0.101	0.129	0.161	0.196	0.235	0.277	0.323	0.373	0.425	0.482	—	—	—
TCFZ3621MTANMC	600/1900 [283/896]	8.55 [0.79]	16/2			0.039	0.039	0.056	0.075	0.095	0.117	0.141	0.166	0.193	0.222	0.252	0.284	0.318	0.353
TCFZ3621MTAAMC TCFZ3621MEANMC	600/1900 [283/896]	7.6 [0.70]	13/3			0.043	0.043	0.053	0.066	0.080	0.096	0.115	0.135	0.158	0.182	0.208	0.237	0.267	0.299
TCFZ4821STAAMC	600/1900 [283/896]	7.6 [0.70]	13/3		3.5 – 4	0.043	0.043	0.053	0.066	0.080	0.096	0.115	0.135	0.158	0.182	0.208	0.237	0.267	0.299
TCFZ4821STANMC	600/1900 [283/896]	8.55 [0.79]	16/2			0.039	0.039	0.056	0.075	0.095	0.117	0.141	0.166	0.193	0.222	0.252	0.284	0.318	0.353
TCFZ6021SEAAMC TCFZ6021STAAMC TCFZ2421HEAAMC	600/1900 [283/896]	7.60 [0.70]	13/3		2 – 5	0.080	0.080	0.092	0.106	0.121	0.136	0.153	0.171	0.190	0.211	0.232	0.254	0.278	0.302
TCFZ4824STANMC	600/1900 [283/896]	8.55 [0.79]	16/2		3.5 – 4	0.039	0.039	0.056	0.075	0.095	0.117	0.141	0.166	0.193	0.222	0.252	0.284	0.318	0.353
TCFZ4824MTANMC	600/1900 [283/896]	9.98 [0.93]	14/3			0.023	0.023	0.038	0.055	0.074	0.095	0.119	0.144	0.171	0.200	0.231	0.264	0.300	0.337
TCFZ6024STANMC TCFZ4824SEANMC	600/1900 [283/896]	9.98 [0.93]	14/3		5	0.023	0.023	0.038	0.055	0.074	0.095	0.119	0.144	0.171	0.200	0.231	0.264	0.300	0.337

[] Designates Metric Conversions

Table 2: Cased Coil Dimensions and Weights

Coil Model TCF	Connections		Cased Coil Dimensions (in) [mm]			Weight	
	Sweat (in.) [mm]		A	B	C	Coil Weight (lbs.) [Kg.]	Shipping Weight (lbs.) [Kg.]
	Liquid	Suction					
	I.D.	I.D.					
2414ST	3/8 [9.53]	3/4 [19.05]	14 [356]	21 [533]	23 ³ / ₁₆ [584]	43 [19]	47 [21]
2417ST/2417SE	3/8 [9.53]	3/4 [19.05]	17 ¹ / ₂ [445]	14 ¹ / ₂ [368]	20 [508]	43 [19]	48 [22]
2417MT/3617ST/3617SE	3/8 [9.53]	3/4 [19.05]	17 ¹ / ₂ [445]	17 ⁷ / ₈ [454]	20 [508]	49 [22]	54 [24]
2421MT/3621ST/2421ME/3621SE	3/8 [9.53]	3/4 [19.05]	21 [533]	17 ¹ / ₂ [445]	20 [508]	51 [23]	60 [27]
3621MT/4821ST/3621ME	3/8 [9.53]	7/8 [22.23]	21 [533]	25 ⁷ / ₈ [657]	28 [711]	71 [32]	78 [35]
2421H/3621M/6021ST/6021SE	3/8 [9.53]	7/8 [22.23]	21 [533]	32 [813]	34 ¹ / ₂ [876]	76 [34]	86 [39]
3624MT/4824ST/4824ST	3/8 [9.53]	3/4 [19.05]	24 ¹ / ₂ [622]	25 ³ / ₈ [645]	32 ¹ / ₂ [826]	83 [37]	93 [42]
4824MT/6024ST/4824SE/6024ME	3/8 [9.53]	7/8 [22.23]	24 ¹ / ₂ [622]	30 ¹ / ₄ [768]	32 ¹ / ₂ [826]	100 [45]	108 [48]

*The 14 inch, 2 ton TCF coil (2414) is part of the "N-Coil" design series, even though the coil shape resembles an "A" coil design.

FIGURE 1: DIMENSIONS CASED

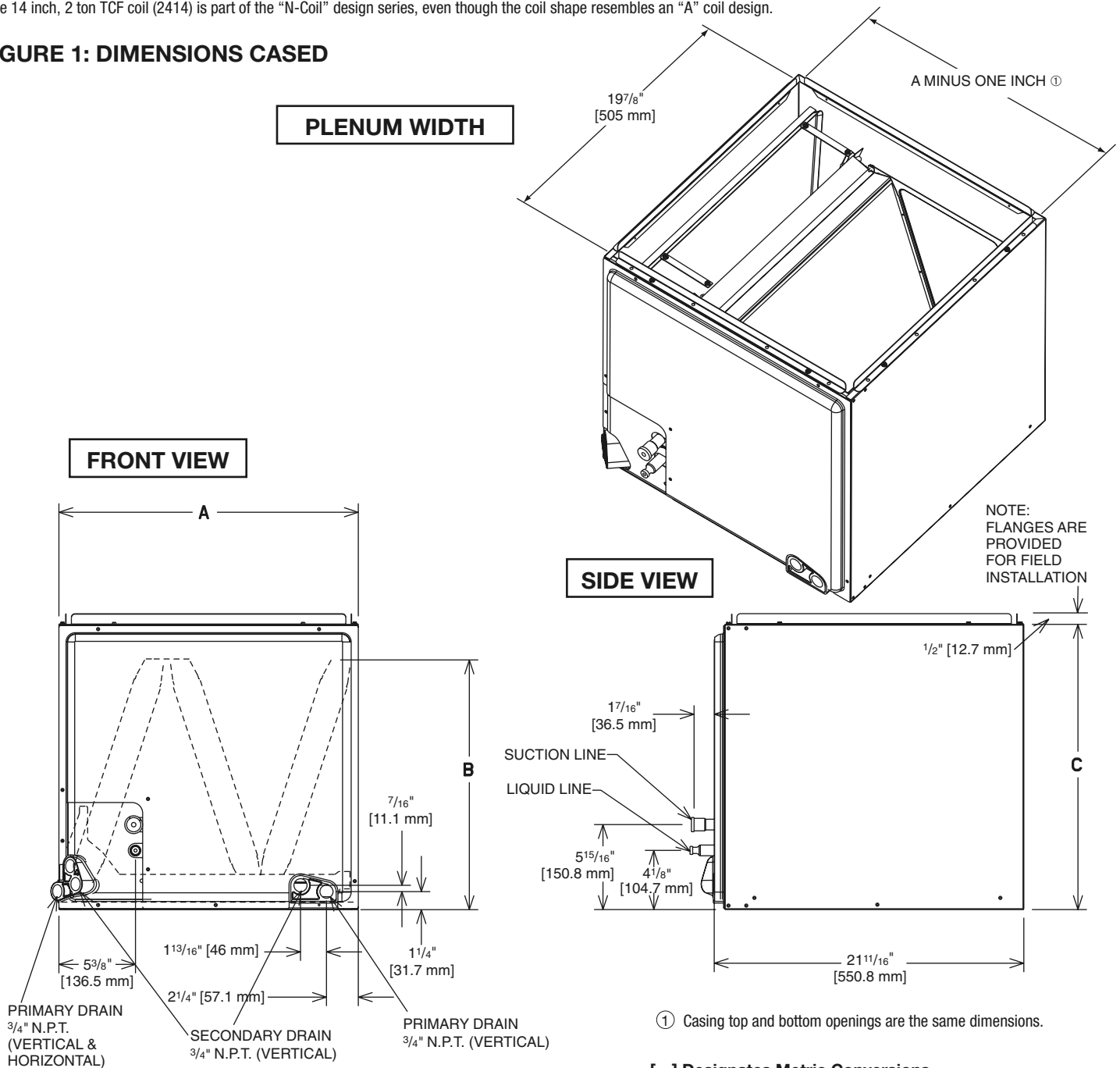

Table 3: Coil Application

Coils can be matched to heating products as listed in table below.

Coil Model TCF	Furnace Width (In.) (mm)	
	Oil	Gas
2414ST 2417ST/2417SE//2417MT 3617ST/ 3617SE	—	14 [356]
2417ST/2417SE/2417MT/ 3617ST/3617SE	17½ [431]	17½ [444] 14 [356]
2421MT/2421ME/2421HE 3621ST/3621MT/3621ME/3621SE 4821ST/6021ST/6021SE	21 [533]	21 [533] 17½ [444]
3624MT 4824ST/4824MT 6024ST/4824SE	24½ [622]	24½ [622] 21 [533]

Accessories

• **PLENUM ADAPTER ACCESSORY
RXBA-AE**

This plenum adapter accessory is for use with the 24½" wide cased indoor cooling and heat pump coils. This allows a 24½" wide cased coil to be installed on a 28" wide oil furnace. This is a field-installed accessory only.

• **RXBA-AC (Upflow/Horizontal)**

These plenum adapter accessories are for use when a cooling coil is matched with a gas furnace of one smaller size.

• **HORIZONTAL ADAPTER KIT RXHH (See Figure 2)**

This horizontal adapter kit is used to convert a upflow or downflow coil (*VUA) for a horizontal application. See Table 4 to order the proper horizontal adapter kit.

Table 4: Horizontal Adapter Kit Model No.

Coil Model	Horizontal Adapter Kit Model No.
2414S	RXHH-A01
2417S	RXHH-A02
2417M/2421M/3617S/ 3621S/2421H	RXHH-A03
3621M/3624M/ 4821S/4824S	RXHH-A04
4824M/ 6024S	RXHH-A05
2421H/3621M/4821M/ 6021S	RXHH-A06

FIGURE 2: HORIZONTAL ADAPTER KIT ILLUSTRATION

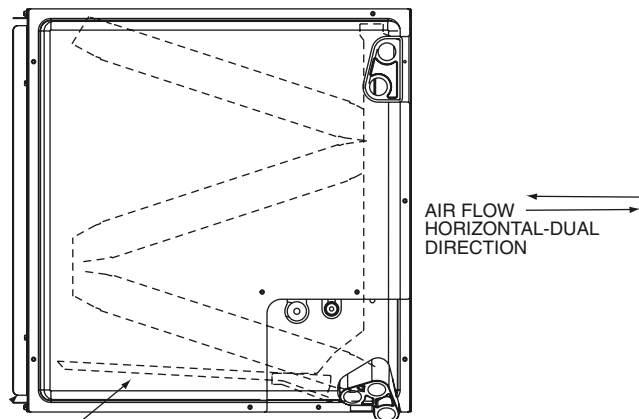

HORIZONTAL ADAPTER KIT (RXHH-)

• **INDOOR COIL CASING- RXBC (See Table 5)**

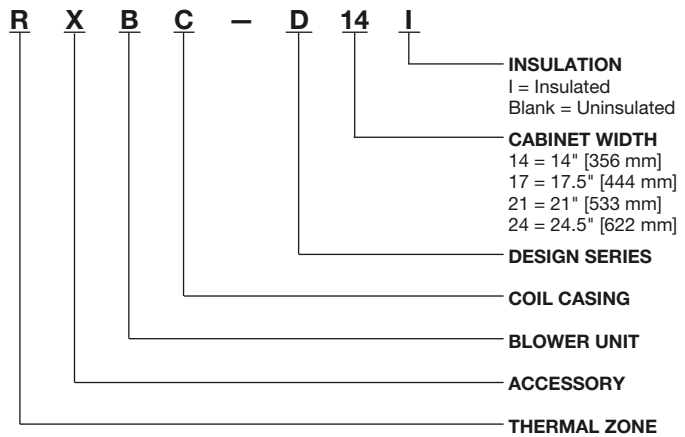

Table 5: Unit Dimensions and Weights- RXBC Indoor Coil Casings

Model Number	Width (in.) [mm]	Height (in.) [mm]	Depth (in.) [mm]	Unit Weight		Supply Air/Return Air Openings	
				Weight (lbs.) [Kg.]	Ship. Wt. (lbs.) [Kg.]	Width (in.) [mm]	Depth (in.) [mm]
RXBC-D14AI	14 [356]	23 ³ / ₁₆ [589]	21 ⁵ / ₈ [549]	19 [9]	23 [10]	13 [330]	19 ³¹ / ₃₂ [508]
RXBC-D17AI	17½ [445]	20 [508]		18 [8]	23 [10]	16½ [419]	
RXBC-D21AI	21 [533]	20 [508]		20 [9]	26 [12]	20 [508]	
RXBC-D21BI	21 [533]	28 [711]		27 [12]	36 [17]	20 [508]	
RXBC-D24AI	24½ [622]	32½ [826]		34 [16]	44 [20]	23½ [597]	

Table 6: Uncased Coil Adapter Kit

Uncased Coil Adapter Model Number RXBA	A Width (in.) [mm]	Uncased Coil Model RCFP
B14x20	13 ¹ / ₈ [333]	-HUxx14
B17x20	16 ⁵ / ₈ [422]	-HUxx17
B21x20	20 ¹ / ₈ [511]	-HUxx21
B24x20	23 ⁵ / ₈ [599]	-HUxx24

[] Designates Metric Conversions

Accessories (cont.)

• UNCASSED COIL ADAPTER KIT

RXBA- (See Figure 3 & 4)

This uncased coil adapter kit is used to adapt the coil to a furnace or ductwork. See Table 6 to order the proper adapter kit. Each kit contains a quantity of 20 adapters.

FIGURE 3: UNCASSED COIL ADAPTER KIT ILLUSTRATION

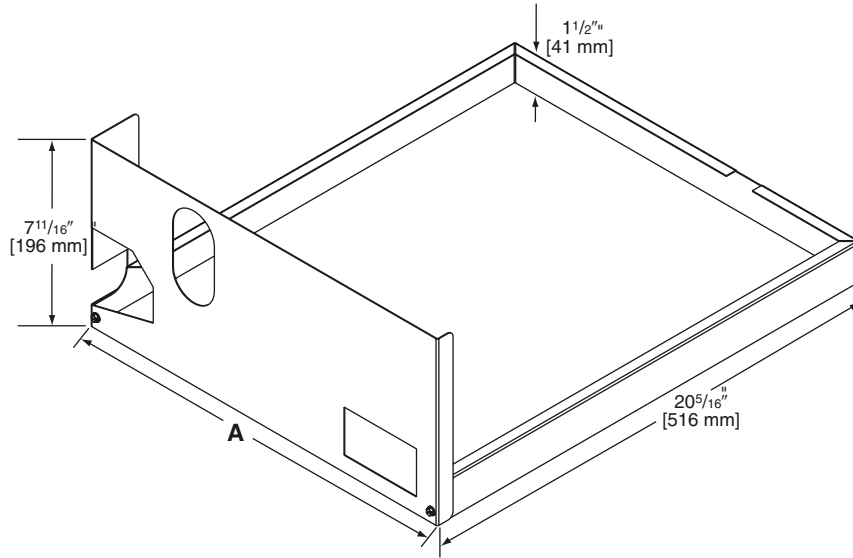
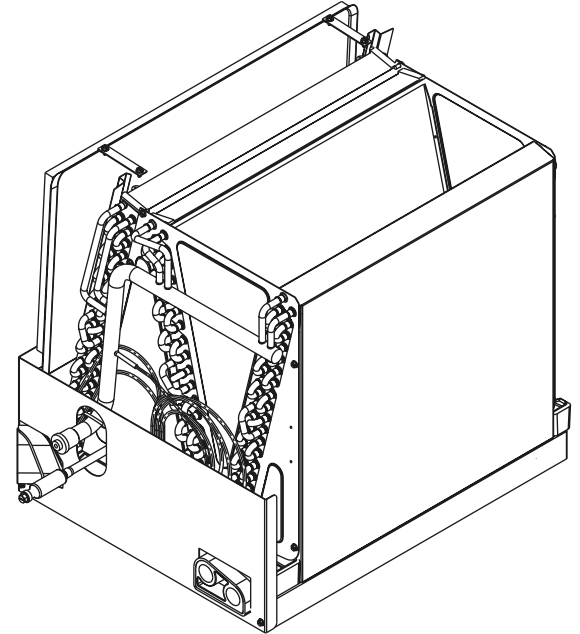

FIGURE 4: UNCASSED COIL ADAPTER KIT ASSEMBLED



Note: Sliding the coil into the coil rail before attaching coil rack front.

[] Designates Metric Conversions



GENERAL TERMS OF LIMITED WARRANTY*

Thermal Zone™ will furnish a replacement for any part of this product which fails in normal use and service within the applicable period stated, in accordance with the terms of the limited warranty.

***For complete details of the Limited and Conditional Warranties, including applicable terms and conditions, contact your local contractor or the Manufacturer for a copy of the product warranty certificate.**

Conditional Parts
(Registration Required)..... Ten (10) Years

"In keeping with its policy of continuous progress and product improvement, Thermal Zone reserves the right to make changes without notice."