



# DEDICATED HORIZONTAL PACKAGE HEAT PUMP

FORM NO. PTZ-790

**TZHH4 14 SEER**  
NOMINAL SIZES 2-5 TONS [7.0-17.6 kW]

**TZHH6 15/16 SEER**  
NOMINAL SIZES 2-5 TONS [7.0-17.6 kW]



Manufactured for  
**Thermal Zone®**  
Philadelphia, PA



*"Proper sizing and installation of equipment is critical to achieve optimal performance.  
Ask your Contractor for details or visit [www.energystar.gov](http://www.energystar.gov)."*

## TABLE OF CONTENTS

Unit Features & Benefits .....	3-6
Model Number Identification .....	7
General Data	
TZHH4 .....	8-11
TZHH6 .....	12-14
General Data Notes .....	15
Gross Systems Performance Data	
TZHH4 Cooling .....	16-20
TZHH6 Cooling .....	21-23
TZHH4 Heating .....	24-28
TZHH6 Heating .....	29-31
Indoor Airflow Performance TZHH4.....	32-33
Indoor Airflow Performance TZHH6.....	34-35
Electrical Data	
TZHH4 .....	36-37
TZHH6.....	38
Electric Heater Kits .....	39-41
Dimensional Data .....	42
Typical Installations .....	43
Limited Warranty .....	44



The TZHH4 & TZHH6 series of Package Heat Pumps are designed to be the most efficient, quickest to install, easiest to service, and most reliable units in the industry – while still maintaining an affordable price. This platform provides you with a full line of nominal capacities from 2 through 5 tons. TZHH4 models are 14 SEER and TZHH6 models are 15/16 SEER, each AHRI-certified.

As with all units offered by Thermal Zone, we started our design process with input from the customer. From fan grille to the base rails, Thermal Zone has combined 30 years worth of package unit design experience with input from Dealers to meet the latest application requirements.

Starting at the bottom, the base rails (1) allow for separation between the unit base and the ground level, protecting the base from ground moisture and providing air circulation around the unit. Constructed from sturdy 18-gauge G-90 sheet metal, the base rails also allow for easier maneuverability during installation.

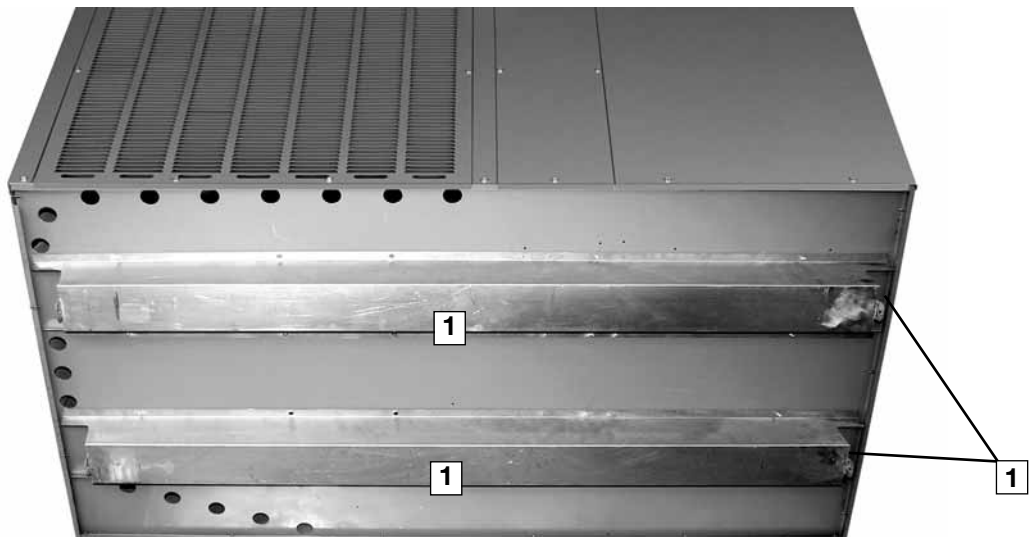



To provide flexibility in space-limited installations, the unit can be installed flush to the structure without blocking airflow over the outdoor coil or making any screws inaccessible for maintenance. Furthermore, the cabinet is a slim 33" wide. Full-louver coil protection (2) makes Thermal Zone unique in the industry and also totally protects the outdoor coil from vandalism and weather extremes.

Two round 14" duct collar (3) are included with the unit, which makes attaching duct a snap. The collar is crimped around the leading edge, making it easier to install duct onto the collar. A metal bead around the circumference prevents the attached ducting from sliding off after installation.

Keeping service technicians in mind, Thermal Zone takes pride providing easy access to internal components. The outdoor-section top cover (4) is easily removed to allow access to the scroll compressor (5), outdoor fan motor (6), and refrigerant tubing (7).

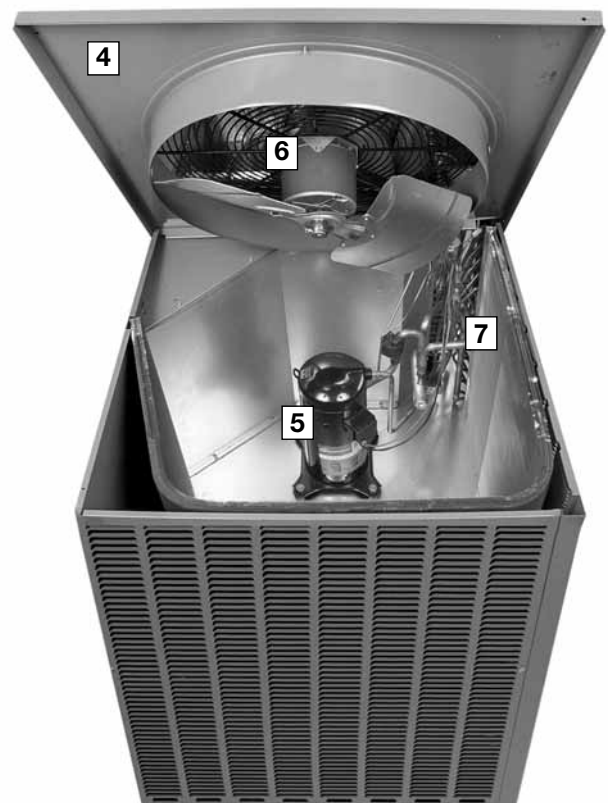

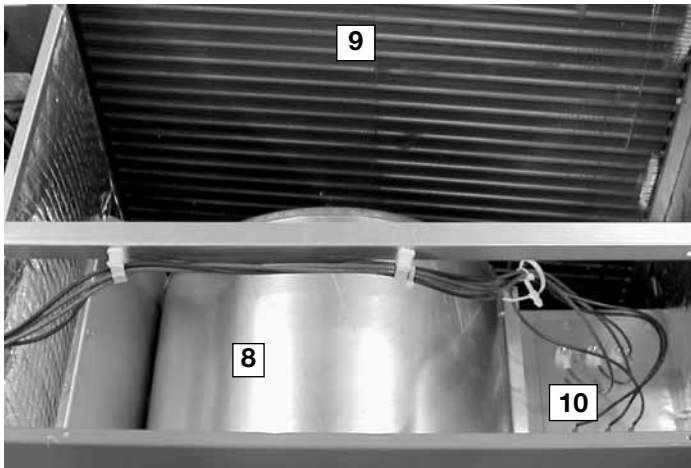

The indoor-section top cover also easily opens to access the removable blower housing and motor (8). This also gains total access to the indoor coil for cleaning and service (9).

The indoor motor and blower system will achieve nominal 400 CFM per ton up to a minimum of .8 inches of static pressure, which helps to eliminate customer dissatisfaction over poor air-flow brought about by high-static duct designs.

Optional electric heat (10) can be easily installed in the field, with either dual- or single-point power, and is designed to easily install into the unit. Electric heat can also be specified as factory installed.

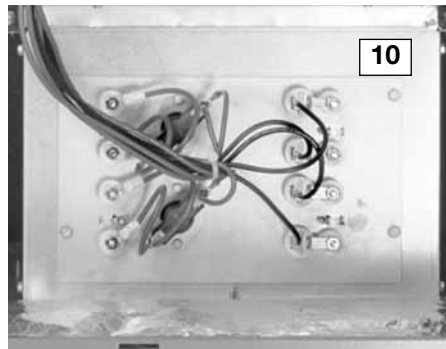

The controls are located in a large, easy-to-access control box (11), which provides plenty of space in which to troubleshoot. A demand defrost control (12) is used to manage the defrost cycle. The transformer (13) is protected by an in-line fuse, which protects the transformer during a low-voltage electrical short. The low-voltage (14) and high-voltage (15) wiring connections are easily accessed and have ample room around which to maneuver. Troubleshooting is further aided with number- and color-coded wiring, which corresponds with the large, easy-to-read wiring diagram located on the inside of the control box access panel.

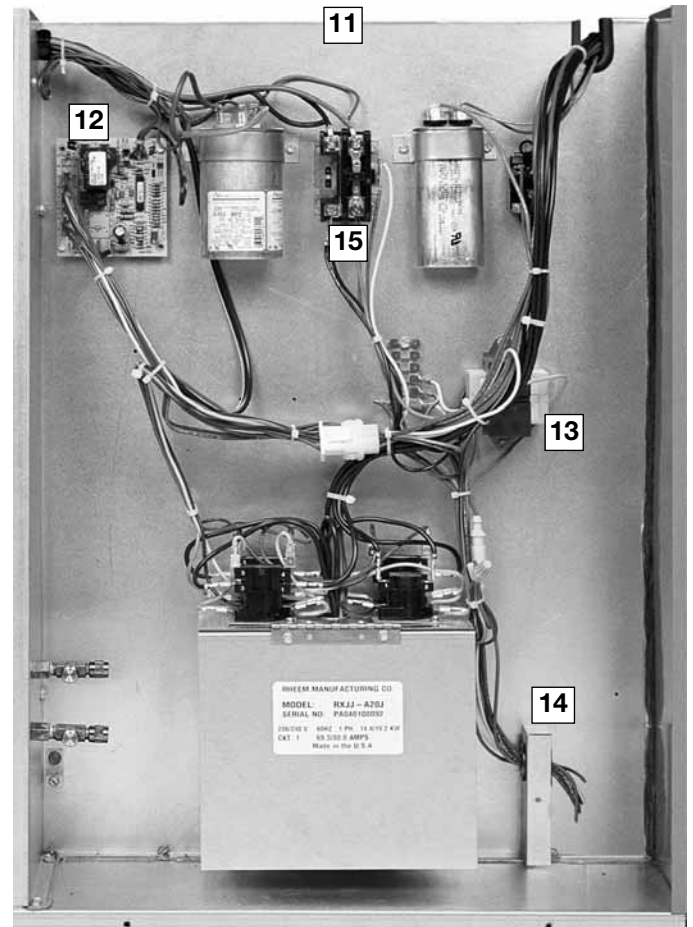

High and low pressure can easily and accurately be measured using the two gauge ports (16) located inside the control box.

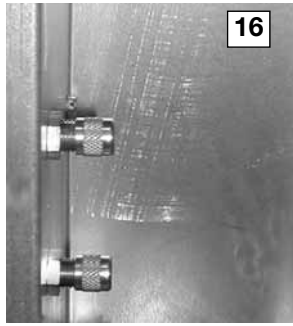

Foil-faced insulation is securely glued and captured to the cabinet. On the base of the unit, closed-cell insulation is used to prevent moisture from being absorbed and help reduce mold content to provide better indoor air quality.

For reliability and long-lasting operation, Thermal Zone uses 100% scroll compressor technology (19) on all package platforms. With over 18 years of history, the scroll compressor has proven to be reliable, efficient, and quiet during operation.

(Note: The TZHH6 A060 uses a two stage scroll compressor).



A small side panel grants access to a removable, sloped drain pan (17), which helps to ensure indoor air quality (IAQ) throughout the life of the unit. A 3/4" drain trap (18) assembly is provided for convenience.

"Patent 7,430,877"



Low pressure control standard on all models (20).  
High pressure control standard on -060 model.

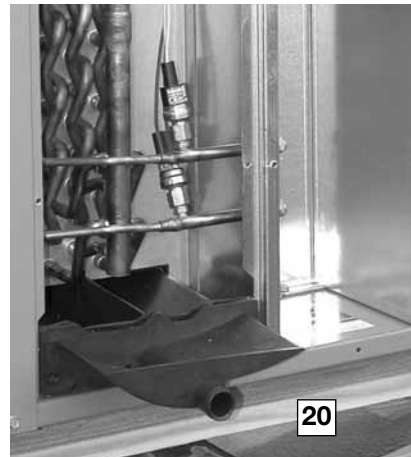

**TZ HH 4 – A 024 J K 010**

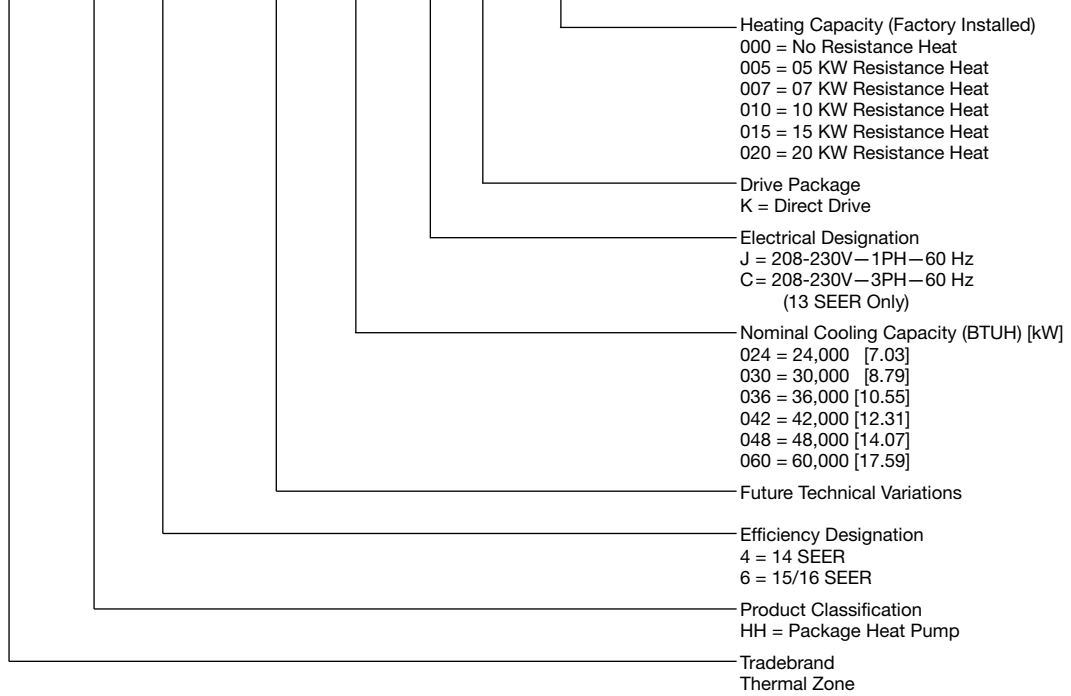

[ ] Designates Metric Conversions

## NOMINAL SIZES 2-5 TONS [7-17.6 kW]

Model TZHH4	A024JK	A030JK	A036CK	A036JK
<b>Cooling Performance<sup>1</sup></b>				
Gross Cooling Capacity Btu [kW]	24,000 [7.03]	29,400 [8.61]	36,000 [10.55]	36,000 [10.55]
EER/SEER <sup>2</sup>	12/14	12.05/14	11.6/14	11.6/14
Nominal CFM/AHRI Rated CFM [L/s]	800/800 [378/378]	1000/1000 [472/472]	1200/1200 [566/566]	1200/1200 [566/566]
AHRI Net Cooling Capacity Btu [kW]	23,600 [6.91]	29,000 [8.5]	35,400 [10.37]	35,400 [10.37]
Net Sensible Capacity Btu [kW]	18,400 [5.39]	23,000 [6.74]	27,600 [8.09]	27,600 [8.09]
Net Latent Capacity Btu [kW]	5,200 [1.52]	6,000 [1.76]	7,800 [2.29]	7,800 [2.29]
Net System Power kW	1.97	2.41	3.05	3.05
<b>Heating Performance (Heat Pumps)<sup>3</sup></b>				
Heating Input Btu [kW] Rating	23,200 [6.8]	28,000 [8.2]	34,200 [10.02]	34,200 [10.02]
System Power KW/COP	1.93/3.5	2.27/3.62	2.78/3.6	2.78/3.6
Low Temp. Btuh [kW] Rating	13,200 [3.87]	15,200 [4.45]	19,000 [5.57]	19,000 [5.57]
System Power KW/COP	1.71/2.26	2.01/2.22	2.48/2.24	2.48/2.24
HSPF (Btu/Watts-hr)	8.0	8.0	8.0	8.0
<b>Compressor</b>				
No./Type	1/Scroll	1/Scroll	1/Scroll	1/Scroll
<b>Outdoor Sound Rating (dB)<sup>4</sup></b>				
	76	76	76	76
<b>Outdoor Coil—Fin Type</b>				
Tube Type	Louvered	Louvered	Louvered	Louvered
Tube Size in. [mm] OD	Rifled	Rifled	Rifled	Rifled
Face Area sq. ft. [sq. m]	0.375 [9.5]	0.375 [9.5]	0.375 [9.5]	0.375 [9.5]
Rows / FPI [FPcm]	10.44 [0.97]	12.65 [1.18]	12.65 [1.18]	12.65 [1.18]
Refrigerant Control	1 / 20 [8]	1 / 20 [8]	1 / 20 [8]	1 / 20 [8]
	TX Valves	TX Valves	TX Valves	TX Valves
<b>Indoor Coil—Fin Type</b>				
Tube Type	Louvered	Louvered	Louvered	Louvered
Tube Size in. [mm]	Rifled	Rifled	Rifled	Rifled
Face Area sq. ft. [sq. m]	0.375 [9.5]	0.375 [9.5]	0.375 [9.5]	0.375 [9.5]
Rows / FPI [FPcm]	4.33 [0.4]	4.33 [0.4]	4.33 [0.4]	4.33 [0.4]
Refrigerant Control	2 / 15 [6]	3 / 13 [5]	3 / 13 [5]	3 / 13 [5]
	TX Valves	TX Valves	TX Valves	TX Valves
Drain Connection No./Size in. [mm]	1/1 [25.4]	1/1 [25.4]	1/1 [25.4]	1/1 [25.4]
<b>Outdoor Fan—Type</b>				
No. Used/Diameter in. [mm]	Propeller	Propeller	Propeller	Propeller
Drive Type/No. Speeds	1/24 [609.6]	1/24 [609.6]	1/24 [609.6]	1/24 [609.6]
CFM [L/s]	Direct/1	Direct/1	Direct/1	Direct/1
No. Motors/HP	3200 [1510]	3200 [1510]	3200 [1510]	3200 [1510]
Motor RPM	1 at 1/3 HP	1 at 1/3 HP	1 at 1/3 HP	1 at 1/3 HP
	825	825	825	825
<b>Indoor Fan—Type</b>				
No. Used/Diameter in. [mm]	FC Centrifugal	FC Centrifugal	FC Centrifugal	FC Centrifugal
Drive Type/No. Speeds	1/10x9 [254x228.6]	1/10x9 [254x228.6]	1/10x9 [254x228.6]	1/10x9 [254x228.6]
No. Motors	Direct/2	Direct/2	Direct/2	Direct/2
Motor HP	1	1	1	1
Motor RPM	1/2	1/2	1/2	1/2
Motor Frame Size	1050	1050	1050	1050
	48	48	48	48
<b>Filter—Type</b>				
Furnished	Field Supplied	Field Supplied	Field Supplied	Field Supplied
(No.) Size Recommended in. [mm]	No	No	No	No
	(1)1x20x16 [25x508x406]	(1)1x20x20 [25x508x508]	(1)1x24x24 [25x610x610]	(1)1x24x24 [25x610x610]
<b>Refrigerant Charge Oz. [g]</b>				
	90 [2552]	93 [2637]	93 [2637]	93 [2637]
<b>Weights</b>				
Net Weight lbs. [kg]	308 [140]	331 [150]	356 [161]	356 [161]
Ship Weight lbs. [kg]	332 [151]	355 [161]	380 [172]	380 [172]

CONTINUED →

See Page 15 for Notes.

[ ] Designates Metric Conversions



## NOMINAL SIZES 2-5 TONS [7-17.6 kW]

Model TZHH4	A037CK	A037JK	A042CK	A042JK
<b>Cooling Performance<sup>1</sup></b>				<b>CONTINUED</b> →
Gross Cooling Capacity Btu [kW]	36,000 [10.55]	36,000 [10.55]	44,000 [12.89]	44,000 [12.89]
EER/SEER <sup>2</sup>	12/14	12/14	11.85/14	11.85/14
Nominal CFM/AHRI Rated CFM [L/s]	1200/1200 [566/566]	1200/1200 [566/566]	1400/1450 [661/684]	1400/1450 [661/684]
AHRI Net Cooling Capacity Btu [kW]	35,400 [10.37]	35,400 [10.37]	43,000 [12.6]	43,000 [12.6]
Net Sensible Capacity Btu [kW]	27,600 [8.09]	27,600 [8.09]	31,800 [9.32]	31,800 [9.32]
Net Latent Capacity Btu [kW]	7,800 [2.29]	7,800 [2.29]	11,200 [3.28]	11,200 [3.28]
Net System Power kW	3.05	3.05	3.63	3.63
<b>Heating Performance (Heat Pumps)<sup>3</sup></b>				
Heating Input Btu [kW] Rating	34,200 [10.02]	34,200 [10.02]	38,500 [11.28]	38,500 [11.28]
System Power KW/COP	2.78/3.6	2.78/3.6	3.31/3.4	3.31/3.4
Low Temp. Btuh [kW] Rating	19,000 [5.57]	19,000 [5.57]	21,800 [6.39]	21,800 [6.39]
System Power KW/COP	2.48/2.24	2.48/2.24	3/2.06	3/2.06
HSPF (Btu/Watts-hr)	8	8	8.1	8.0
<b>Compressor</b>				
No./Type	1/Scroll	1/Scroll	1/Scroll	1/Scroll
<b>Outdoor Sound Rating (dB)<sup>4</sup></b>	76	76	78	78
<b>Outdoor Coil—Fin Type</b>	Louvered	Louvered	Louvered	Louvered
Tube Type	Rifled	Rifled	Rifled	Rifled
Tube Size in. [mm] OD	0.375 [9.5]	0.375 [9.5]	0.375 [9.5]	0.375 [9.5]
Face Area sq. ft. [sq. m]	12.65 [1.18]	12.65 [1.18]	16.54 [1.54]	16.54 [1.54]
Rows / FPI [FPcm]	1 / 20 [8]	1 / 20 [8]	1 / 22 [9]	1 / 22 [9]
Refrigerant Control	TX Valves	TX Valves	TX Valves	TX Valves
<b>Indoor Coil—Fin Type</b>	Louvered	Louvered	Louvered	Louvered
Tube Type	Rifled	Rifled	Rifled	Rifled
Tube Size in. [mm]	0.375 [9.5]	0.375 [9.5]	0.375 [9.5]	0.375 [9.5]
Face Area sq. ft. [sq. m]	4.33 [0.4]	4.33 [0.4]	5.78 [0.54]	5.78 [0.54]
Rows / FPI [FPcm]	3 / 13 [5]	3 / 13 [5]	3 / 13 [5]	3 / 13 [5]
Refrigerant Control	TX Valves	TX Valves	TX Valves	TX Valves
Drain Connection No./Size in. [mm]	1/1 [25.4]	1/1 [25.4]	1/1 [25.4]	1/1 [25.4]
<b>Outdoor Fan—Type</b>	Propeller	Propeller	Propeller	Propeller
No. Used/Diameter in. [mm]	1/24 [609.6]	1/24 [609.6]	1/24 [609.6]	1/24 [609.6]
Drive Type/No. Speeds	Direct/1	Direct/1	Direct/1	Direct/1
CFM [L/s]	3200 [1510]	3200 [1510]	4200 [1982]	4200 [1982]
No. Motors/HP	1 at 1/3 HP	1 at 1/3 HP	1 at 1/3 HP	1 at 1/3 HP
Motor RPM	850	850	1075	1075
<b>Indoor Fan—Type</b>	FC Centrifugal	FC Centrifugal	FC Centrifugal	FC Centrifugal
No. Used/Diameter in. [mm]	1/10x9 [254x229]	1/10x9 [254x229]	1/11x9 [279.4x228.6]	1/11x9 [279.4x228.6]
Drive Type/No. Speeds	Direct/2	Direct/2	Direct/2	Direct/2
No. Motors	1	1	1	1
Motor HP	1/2	1/2	3/4	3/4
Motor RPM	1050	1050	1050	1050
Motor Frame Size	48	48	48	48
<b>Filter—Type</b>	Field Supplied	Field Supplied	Field Supplied	Field Supplied
Furnished	No	No	No	No
(No.) Size Recommended in. [mm]	(1)1x24x24 [25x610x610]	(1)1x24x24 [25x610x610]	(1)1x24x24 [25x610x610]	(1)1x24x24 [25x610x610]
<b>Refrigerant Charge Oz. [g]</b>	93 [2637]	93 [2637]	128 [3629]	128 [3629]
<b>Weights</b>				
Net Weight lbs. [kg]	356 [161]	356 [161]	408 [185]	408 [185]
Ship Weight lbs. [kg]	380 [172]	380 [172]	434 [197]	434 [197]

See Page 15 for Notes.

[ ] Designates Metric Conversions

## NOMINAL SIZES 2-5 TONS [7-17.6 kW]

Model TZHH4	A043CK	A043JK	A048CK	A048JK
<b>Cooling Performance<sup>1</sup></b>				
Gross Cooling Capacity Btu [kW]	43,500 [12.75]	43,500 [12.75]	49,000 [14.36]	49,000 [14.36]
EER/SEER <sup>2</sup>	12/14	12/14	11.8/14	11.8/14
Nominal CFM/AHRI Rated CFM [L/s]	1400/1425 [661/672]	1400/1425 [661/672]	1600/1550 [755/731]	1600/1550 [755/731]
AHRI Net Cooling Capacity Btu [kW]	42,500 [12.45]	42,500 [12.45]	48,000 [14.06]	48,000 [14.06]
Net Sensible Capacity Btu [kW]	32,500 [9.52]	32,500 [9.52]	36,800 [10.78]	36,800 [10.78]
Net Latent Capacity Btu [kW]	10,000 [2.93]	10,000 [2.93]	11,200 [3.28]	11,200 [3.28]
Net System Power kW	3.44	3.44	4.07	4.07
<b>Heating Performance (Heat Pumps)<sup>3</sup></b>				
Heating Input Btu [kW] Rating	40,000 [11.72]	40,000 [11.72]	42,000 [12.31]	42,000 [12.31]
System Power KW/COP	3.32/3.5	3.32/3.5	3.59/3.66	3.59/3.66
Low Temp. Btuh [kW] Rating	22,000 [6.45]	22,000 [6.45]	25,400 [7.44]	25,400 [7.44]
System Power KW/COP	3/2.14	3/2.14	3.22/2.3	3.22/2.3
HSPF (Btu/Watts-hr)	8	8	8.0	8.0
<b>Compressor</b>				
No./Type	1/Scroll	1/Scroll	1/Scroll	1/Scroll
<b>Outdoor Sound Rating (dB)<sup>4</sup></b>				
	78	78	78	78
<b>Outdoor Coil—Fin Type</b>				
Tube Type	Louvered	Louvered	Louvered	Louvered
Tube Size in. [mm] OD	Rifled	Rifled	Rifled	Rifled
Face Area sq. ft. [sq. m]	0.375 [9.5]	0.375 [9.5]	0.375 [9.5]	0.375 [9.5]
Rows / FPI [FPcm]	13.45 [1.25]	13.45 [1.25]	16.54 [1.54]	16.54 [1.54]
Refrigerant Control	2 / 18 [7]	2 / 18 [7]	1 / 22 [9]	1 / 22 [9]
	TX Valves	TX Valves	TX Valves	TX Valves
<b>Indoor Coil—Fin Type</b>				
Tube Type	Louvered	Louvered	Louvered	Louvered
Tube Size in. [mm]	Rifled	Rifled	Rifled	Rifled
Face Area sq. ft. [sq. m]	0.375 [9.5]	0.375 [9.5]	0.375 [9.5]	0.375 [9.5]
Rows / FPI [FPcm]	5.78 [0.54]	5.78 [0.54]	5.78 [0.54]	5.78 [0.54]
Refrigerant Control	3 / 13 [5]	3 / 13 [5]	3 / 13 [5]	3 / 13 [5]
Drain Connection No./Size in. [mm]	TX Valves	TX Valves	TX Valves	TX Valves
	1/1 [25.4]	1/1 [25.4]	1/1 [25.4]	1/1 [25.4]
<b>Outdoor Fan—Type</b>				
No. Used/Diameter in. [mm]	Propeller	Propeller	Propeller	Propeller
Drive Type/No. Speeds	1/24 [609.6]	1/24 [609.6]	1/24 [609.6]	1/24 [609.6]
CFM [L/s]	Direct/1	Direct/1	Direct/1	Direct/1
No. Motors/HP	4200 [1982]	4200 [1982]	4200 [1982]	4200 [1982]
Motor RPM	1 at 1/3 HP	1 at 1/3 HP	1 at 1/3 HP	1 at 1/3 HP
	1075	1075	1075	1075
<b>Indoor Fan—Type</b>				
No. Used/Diameter in. [mm]	FC Centrifugal	FC Centrifugal	FC Centrifugal	FC Centrifugal
Drive Type/No. Speeds	1/11x9 [279x229]	1/11x9 [279x229]	1/11x9 [279.4x228.6]	1/11x9 [279.4x228.6]
No. Motors	Direct/2	Direct/2	Direct/2	Direct/2
Motor HP	1	1	1	1
Motor RPM	3/4	3/4	3/4	3/4
Motor Frame Size	1050	1050	1050	1050
	48	48	48	48
<b>Filter—Type</b>				
Furnished	Field Supplied	Field Supplied	Field Supplied	Field Supplied
(No.) Size Recommended in. [mm]	No	No	No	No
	(1)1x24x24 [25x610x610]	(1)1x24x24 [25x610x610]	(1)1x24x24 [25x610x610]	(1)1x24x24 [25x610x610]
<b>Refrigerant Charge Oz. [g]</b>				
	161 [4564]	161 [4564]	120 [3402]	120 [3402]
<b>Weights</b>				
Net Weight lbs. [kg]	408 [185]	408 [185]	429 [195]	429 [195]
Ship Weight lbs. [kg]	434 [197]	434 [197]	455 [206]	455 [206]

See Page 15 for Notes.

[ ] Designates Metric Conversions

## NOMINAL SIZES 2-5 TONS [7-17.6 kW]

Model TZHH4	A049CK	A049JK	A060CK	A060JK
<b>Cooling Performance<sup>1</sup></b>				
Gross Cooling Capacity Btu [kW]	49,000 [14.36]	49,000 [14.36]	61,000 [17.87]	61,000 [17.87]
EER/SEER <sup>2</sup>	12/14	12/14	12.0/14	12.0/14
Nominal CFM/AHRI Rated CFM [L/s]	1600/1550 [755/731]	1600/1550 [755/731]	2000/1900 [944/897]	2000/1900 [944/897]
AHRI Net Cooling Capacity Btu [kW]	48,000 [14.06]	48,000 [14.06]	59,500 [17.43]	59,500 [17.43]
Net Sensible Capacity Btu [kW]	36,800 [10.78]	36,800 [10.78]	45,300 [13.27]	45,300 [13.27]
Net Latent Capacity Btu [kW]	11,200 [3.28]	11,200 [3.28]	14,200 [4.16]	14,200 [4.16]
Net System Power kW	4	4	5.00	5.00
<b>Heating Performance (Heat Pumps)<sup>3</sup></b>				
Heating Input Btu [kW] Rating	42,000 [12.31]	42,000 [12.31]	59,500 [17.43]	59,500 [17.43]
System Power KW/COP	3.59/3.66	3.59/3.66	4.74/3.72	4.74/3.72
Low Temp. Btuh [kW] Rating	25,400 [7.44]	25,400 [7.44]	36,600 [10.72]	36,600 [10.72]
System Power KW/COP	3.22/2.3	3.22/2.3	4.26/2.54	4.26/2.54
HSPF (Btu/Watts-hr)	8	8	8	8
<b>Compressor</b>				
No./Type	1/Scroll	1/Scroll	1/Scroll	1/Scroll
<b>Outdoor Sound Rating (dB)<sup>4</sup></b>				
	78	78	78	78
<b>Outdoor Coil—Fin Type</b>				
Tube Type	Louvered	Louvered	Louvered	Louvered
Tube Size in. [mm] OD	Rifled	Rifled	Rifled	Rifled
Tube Size in. [mm] OD	0.375 [9.5]	0.375 [9.5]	0.375 [9.5]	0.375 [9.5]
Face Area sq. ft. [sq. m]	16.54 [1.54]	16.54 [1.54]	16.54 [1.54]	16.54 [1.54]
Rows / FPI [FPcm]	1 / 22 [9]	1 / 22 [9]	2 / 18 [7]	2 / 18 [7]
Refrigerant Control	TX Valves	TX Valves	TX Valves	TX Valves
<b>Indoor Coil—Fin Type</b>				
Tube Type	Louvered	Louvered	Louvered	Louvered
Tube Type	Rifled	Rifled	Rifled	Rifled
Tube Size in. [mm]	0.375 [9.5]	0.375 [9.5]	0.375 [9.5]	0.375 [9.5]
Face Area sq. ft. [sq. m]	5.78 [0.54]	5.78 [0.54]	5.78 [0.54]	5.78 [0.54]
Rows / FPI [FPcm]	3 / 13 [5]	3 / 13 [5]	4 / 13 [5]	4 / 13 [5]
Refrigerant Control	TX Valves	TX Valves	TX Valves	TX Valves
Drain Connection No./Size in. [mm]	1/1 [25.4]	1/1 [25.4]	1/1 [25.4]	1/1 [25.4]
<b>Outdoor Fan—Type</b>				
No. Used/Diameter in. [mm]	Propeller	Propeller	Propeller	Propeller
Drive Type/No. Speeds	1/24 [609.6]	1/24 [609.6]	1/24 [609.6]	1/24 [609.6]
CFM [L/s]	Direct/1	Direct/1	Direct/1	Direct/1
No. Motors/HP	4200 [1982]	4200 [1982]	4000 [1888]	4000 [1888]
Motor RPM	1 at 1/3 HP	1 at 1/3 HP	1 at 1/3 HP	1 at 1/3 HP
	908	908	1075	1075
<b>Indoor Fan—Type</b>				
No. Used/Diameter in. [mm]	FC Centrifugal	FC Centrifugal	FC Centrifugal	FC Centrifugal
Drive Type/No. Speeds	1/11x9 [279x229]	1/11x9 [279x229]	1/11x9 [279.4x228.6]	1/11x9 [279.4x228.6]
No. Motors	Direct/2	Direct/2	Direct/2	Direct/2
Motor HP	1	1	1	1
Motor RPM	3/4	3/4	1	1
Motor Frame Size	1050	1050	1050	1050
	48	48	48	48
<b>Filter—Type</b>				
Furnished	Field Supplied	Field Supplied	Field Supplied	Field Supplied
(No.) Size Recommended in. [mm]	No	No	No	No
	(1)1x24x24 [25x610x610]	(1)1x24x24 [25x610x610]	(1)1x24x24 [25x610x610]	(1)1x24x24 [25x610x610]
<b>Refrigerant Charge Oz. [g]</b>				
	120 [3402]	120 [3402]	193 [5472]	193 [5472]
<b>Weights</b>				
Net Weight lbs. [kg]	429 [195]	429 [195]	481 [218]	481 [218]
Ship Weight lbs. [kg]	455 [206]	455 [206]	507 [230]	507 [230]

See Page 15 for Notes.

[ ] Designates Metric Conversions

## NOMINAL SIZES 2-5 TONS [7-17.6 kW]

Model TZHH6	A024JK	A030JK	A036JK	A042JK
<b>Cooling Performance<sup>1</sup></b>				<b>CONTINUED</b> →
Gross Cooling Capacity Btu [kW]	24,400 [7.15]	29,600 [8.67]	35,000 [10.25]	43,000 [12.6]
EER/SEER <sup>2</sup>	13/16	13/16	13/16	13/16
Nominal CFM/AHRI Rated CFM [L/s]	800/900 [378/425]	1000/1000 [472/472]	1200/1200 [566/566]	1400/1425 [661/672]
AHRI Net Cooling Capacity Btu [kW]	24,000 [7.03]	29,200 [8.56]	34,400 [10.08]	42,000 [12.31]
Net Sensible Capacity Btu [kW]	20,000 [5.86]	23,050 [6.75]	27,000 [7.91]	32,200 [9.43]
Net Latent Capacity Btu [kW]	4,000 [1.17]	6,150 [1.8]	7,400 [2.17]	9,800 [2.87]
Net System Power kW	1.85	2.13	2.58	3.14
<b>Heating Performance (Heat Pumps)<sup>3</sup></b>				
Heating Input Btu [kW] Rating	23,800 [6.97]	28,800 [8.44]	33,200 [9.73]	39,500 [11.57]
System Power KW/COP	1.79/3.9	2.11/4	2.63/3.7	2.89/4
Low Temp. Btuh [kW] Rating	11,700 [3.43]	16,000 [4.69]	18,600 [5.45]	22,400 [6.56]
System Power KW/COP	1.65/2.08	1.95/2.4	2.37/2.3	2.74/2.4
HSPF (Btu/Watts-hr)	8.2	8.2	8	8.5
<b>Compressor</b>				
No./Type	1/Scroll	1/Scroll	1/Scroll	1/Scroll
<b>Outdoor Sound Rating (dB)<sup>4</sup></b>	76	76	76	76
<b>Outdoor Coil—Fin Type</b>	Louvered	Louvered	Louvered	Louvered
Tube Type	Rifled	Rifled	Rifled	Rifled
Tube Size in. [mm] OD	0.375 [9.5]	0.375 [9.5]	0.375 [9.5]	0.375 [9.5]
Face Area sq. ft. [sq. m]	12.12 [1.13]	16.54 [1.54]	16.54 [1.54]	15.85 [1.47]
Rows / FPI [FPcm]	2 / 18 [7]	2 / 18 [7]	2 / 18 [7]	2 / 18 [7]
Refrigerant Control	TX Valves	TX Valves	TX Valves	TX Valves
<b>Indoor Coil—Fin Type</b>	Louvered	Louvered	Louvered	Louvered
Tube Type	Rifled	Rifled	Rifled	Rifled
Tube Size in. [mm]	0.375 [9.5]	0.375 [9.5]	0.375 [9.5]	0.375 [9.5]
Face Area sq. ft. [sq. m]	4.33 [0.4]	5.78 [0.54]	5.78 [0.54]	5.78 [0.54]
Rows / FPI [FPcm]	3 / 13 [5]	3 / 13 [5]	3 / 13 [5]	4 / 13 [5]
Refrigerant Control	TX Valves	TX Valves	TX Valves	TX Valves
Drain Connection No./Size in. [mm]	1/1 [25.4]	1/1 [25.4]	1/1 [25.4]	1/1 [25.4]
<b>Outdoor Fan—Type</b>	Propeller	Propeller	Propeller	Propeller
No. Used/Diameter in. [mm]	1/24 [609.6]	1/24 [609.6]	1/24 [609.6]	1/24 [609.6]
Drive Type/No. Speeds	Direct/1	Direct/1	Direct/1	Direct/1
CFM [L/s]	3200 [1510]	3200 [1510]	3200 [1510]	4200 [1982]
No. Motors/HP	1 at 1/3 HP	1 at 1/3 HP	1 at 1/3 HP	1 at 1/3 HP
Motor RPM	825	825	825	1075
<b>Indoor Fan—Type</b>	FC Centrifugal	FC Centrifugal	FC Centrifugal	FC Centrifugal
No. Used/Diameter in. [mm]	1/10x9 [254x229]	1/10x9 [254x229]	1/10x9 [254x229]	1/11x9 [279x229]
Drive Type/No. Speeds	Direct/2	Direct/2	Direct/2	Direct/2
No. Motors	1	1	1	1
Motor HP	1/2	1/2	1/2	3/4
Motor RPM	1050	1050	1050	1050
Motor Frame Size	48	48	48	48
<b>Filter—Type</b>	Field Supplied	Field Supplied	Field Supplied	Field Supplied
Furnished	No	No	No	No
(No.) Size Recommended in. [mm]	(1)1x20x16 [25x508x406]	(1)1x20x20 [25x508x508]	(1)1x24x24 [25x610x610]	(1)1x24x24 [25x610x610]
<b>Refrigerant Charge Oz. [g]</b>	176 [4990]	203 [5755]	194 [5500]	206 [5840]
<b>Weights</b>				
Net Weight lbs. [kg]	385 [175]	429 [195]	429 [195]	479 [217]
Ship Weight lbs. [kg]	409 [186]	455 [206]	455 [206]	505 [229]

See Page 15 for Notes.

[ ] Designates Metric Conversions

## NOMINAL SIZES 2-5 TONS [7-17.6 kW]

Model TZHH6	A048JK
<b>Cooling Performance<sup>1</sup></b>	
Gross Cooling Capacity Btu [kW]	46,500 [13.62]
EER/SEER <sup>2</sup>	13/16
Nominal CFM/AHRI Rated CFM [L/s]	1600/1525 [755/720]
AHRI Net Cooling Capacity Btu [kW]	45,500 [13.33]
Net Sensible Capacity Btu [kW]	34,700 [10.17]
Net Latent Capacity Btu [kW]	10,800 [3.16]
Net System Power kW	3.45
<b>Heating Performance (Heat Pumps)<sup>3</sup></b>	
Heating Input Btu [kW] Rating	43,500 [12.75]
System Power KW/COP	3.19/4
Low Temp. Btuh [kW] Rating	23,800 [6.97]
System Power KW/COP	2.79/2.5
HSPF (Btu/Watts-hr)	8.5
<b>Compressor</b>	
No./Type	1/Scroll
<b>Outdoor Sound Rating (dB)<sup>4</sup></b>	
	78
<b>Outdoor Coil—Fin Type</b>	
Tube Type	Louvered
Tube Size in. [mm] OD	Rifled
Face Area sq. ft. [sq. m]	0.375 [9.5]
Rows / FPI [FPcm]	16.54 [1.54]
Refrigerant Control	2 / 18 [7]
	TX Valves
<b>Indoor Coil—Fin Type</b>	
Tube Type	Louvered
Tube Size in. [mm]	Rifled
Face Area sq. ft. [sq. m]	0.375 [9.5]
Rows / FPI [FPcm]	5.78 [0.54]
Refrigerant Control	4 / 13 [5]
Drain Connection No./Size in. [mm]	TX Valves
	1/1 [25.4]
<b>Outdoor Fan—Type</b>	
No. Used/Diameter in. [mm]	Propeller
Drive Type/No. Speeds	1/24 [609.6]
CFM [L/s]	Direct/1
No. Motors/HP	4200 [1982]
Motor RPM	1 at 1/3 HP
	1075
<b>Indoor Fan—Type</b>	
No. Used/Diameter in. [mm]	FC Centrifugal
Drive Type/No. Speeds	1/11x9 [279x229]
No. Motors	Direct/2
Motor HP	1
Motor RPM	3/4
Motor Frame Size	1050
	48
<b>Filter—Type</b>	
Furnished	Field Supplied
(No.) Size Recommended in. [mm]	No
	(1)1x24x24 [25x610x610]
<b>Refrigerant Charge Oz. [g]</b>	
	216 [6124]
<b>Weights</b>	
Net Weight lbs. [kg]	469 [213]
Ship Weight lbs. [kg]	495 [225]

See Page 15 for Notes.

[ ] Designates Metric Conversions

## NOMINAL SIZES 2-5 TONS [7-17.6 kW]

Model TZHH6	A060JK
<b>Cooling Performance<sup>1</sup></b>	
Gross Cooling Capacity (2nd Stage) Btu [kW]	57,500 [16.85]
SEER <sup>2</sup>	15
EER (1st stage / 2nd stage)	12.6/12.0
AHRI Rated CFM (1st / 2nd stage) [L/s]	1400 [660] / 1700 [802]
AHRI Net Cooling Capacity (1st / 2nd stage) Btu [kW]	40,900 [11.98] / 56,000 [16.41]
Net Sensible Capacity (1st / 2nd stage) Btu [kW]	32,850 [9.62] / 41,450 [12.14]
Net Latent Capacity (1st / 2nd stage) Btu [kW]	8,050 [2.35] / 14,550 [4.26]
Net System Power (1st / 2nd stage) [kW]	3.24 / 4.63
<b>Heating Performance (Heat Pumps)<sup>3</sup></b>	
High Temp. (1st stage / 2nd stage) Btu/h [kW] Rating	38,000 [11.13] / 54,800 [16.06]
System Power (1st stage / 2nd stage) COP	3.68/3.82
System Power (1st stage / 2nd stage) KW	3.04/4.2
Low Temp. (1st stage / 2nd stage) Btu/h [kW] Rating	20,800 [6.09] / 31,600 [9.26]
System Power (1st stage / 2nd stage) COP	2.15/2.54
System Power (1st stage / 2nd stage) KW	2.86/3.65
HSPF (Btu/Watts-hr)	8.5
<b>Compressor</b>	
No./Type	1/Scroll
<b>Outdoor Sound Rating (dB)<sup>4</sup></b>	
	78
<b>Outdoor Coil—Fin Type</b>	
Tube Type	Louvered
	Rifled
Tube Size in. [mm] OD	0.375 [9.5]
Face Area sq. ft. [sq. m]	16.54 [1.54]
Rows / FPI [FPcm]	2 / 18 [7]
Refrigerant Control	TX Valves
<b>Indoor Coil—Fin Type</b>	
Tube Type	Louvered
	Rifled
Tube Size in. [mm]	0.375 [9.5]
Face Area sq. ft. [sq. m]	5.78 [0.54]
Rows / FPI [FPcm]	4 / 13 [5]
Refrigerant Control	TX Valves
Drain Connection No./Size in. [mm]	1/1 [25.4]
<b>Outdoor Fan—Type</b>	
	Propeller
No. Used/Diameter in. [mm]	1/24 [609.6]
Drive Type/No. Speeds	Direct/1
CFM [L/s]	4200 [1982]
No. Motors/HP	1 at 1/3 HP
Motor RPM	1075
<b>Indoor Fan—Type</b>	
	FC Centrifugal
No. Used/Diameter in. [mm]	1/11x9 [279x229]
Drive Type/No. Speeds	Direct/2
No. Motors	1
Motor HP	1
Motor RPM	1050
Motor Frame Size	48
<b>Filter—Type</b>	
	Field Supplied
Furnished	No
(NO.) Size Recommended in. [mm x mm x mm]	(1)1x24x24 [25x610x610]
<b>Refrigerant Charge Oz. [g]</b>	
	202 [5727]
<b>Weights</b>	
Net Weight lbs. [kg]	482 [219]
Ship Weight lbs. [kg]	508 [230]

See Page 15 for Notes.

[ ] Designates Metric Conversions

## NOTES:

1. Cooling Performance is rated at 95° F ambient, 80° F entering dry bulb, 67° F entering wet bulb. Gross capacity does not include the effect of fan motor heat. AHRI capacity is net and includes the effect of fan motor heat. Units are suitable for operation to  $\pm 20\%$  of nominal cfm. Units are certified in accordance with the Unitary Air Conditioner Equipment certification program, which is based on AHRI Standard 210/240 or 360.
2. EER and/or SEER are rated at AHRI conditions and in accordance with DOE test procedures.
3. Heating Performance is rated at 47° F ambient, 70° F entering dry bulb for High Temp rating and 17° ambient, 70° F entering dry bulb for Low Temp rating. Performance ratings do include the effect of fan motor heat.
4. Outdoor Sound Rating shown is tested in accordance with AHRI Standard 270.

## GROSS SYSTEMS COOLING PERFORMANCE DATA—TZHH4-A024

		ENTERING INDOOR AIR @ 80°F [26.7°C] dbE ①									
wbE		71°F [21.7°C]			67°F [19.4°C]			63°F [17.2°C]			
CFM [L/s]		960 [453]	800 [378]	640 [302]	960 [453]	800 [378]	640 [302]	960 [453]	800 [378]	640 [302]	
DR ①		.04	.07	.10	.04	.07	.10	.04	.07	.10	
OUTDOOR DRY BULB TEMPERATURE °F [°C]	75 [23.9]	Total BTUH [kW] Sens BTUH [kW] Power	30.4 [8.9] 18.5 [5.4] 1.5	29.3 [8.6] 15.8 [4.6] 1.5	28.3 [8.3] 13.4 [3.9] 1.5	28.5 [8.4] 22.9 [6.7] 1.5	27.5 [8.1] 19.9 [5.8] 1.5	26.5 [7.8] 17.1 [5.0] 1.5	27.0 [7.9] 25.6 [7.5] 1.5	26.0 [7.6] 22.4 [6.6] 1.5	25.1 [7.4] 19.5 [5.7] 1.5
	80 [26.7]	Total BTUH [kW] Sens BTUH [kW] Power	29.5 [8.6] 18.3 [5.4] 1.6	28.5 [8.4] 15.7 [4.6] 1.6	27.4 [8.0] 13.2 [3.9] 1.5	27.6 [8.1] 22.6 [6.6] 1.6	26.6 [7.8] 19.7 [5.8] 1.6	25.7 [7.5] 17.0 [5.0] 1.5	26.1 [7.6] 25.4 [7.5] 1.6	25.2 [7.4] 22.3 [6.5] 1.6	24.3 [7.1] 19.4 [5.7] 1.5
	85 [29.4]	Total BTUH [kW] Sens BTUH [kW] Power	28.6 [8.4] 18.0 [5.3] 1.7	27.6 [8.1] 15.5 [4.6] 1.7	26.6 [7.8] 13.1 [3.8] 1.6	26.7 [7.8] 22.3 [6.5] 1.7	25.8 [7.6] 19.5 [5.7] 1.7	24.9 [7.3] 16.9 [5.0] 1.6	25.2 [7.4] 25.1 [7.4] 1.7	24.3 [7.1] 22.1 [6.5] 1.7	23.4 [6.9] 19.2 [5.6] 1.6
	90 [32.2]	Total BTUH [kW] Sens BTUH [kW] Power	27.7 [8.1] 17.6 [5.2] 1.8	26.7 [7.8] 15.1 [4.4] 1.7	25.8 [7.6] 12.9 [3.8] 1.7	25.8 [7.6] 22.0 [6.5] 1.8	24.9 [7.3] 19.2 [5.6] 1.8	24.0 [7.0] 16.6 [4.9] 1.7	24.3 [7.1] 24.3 [7.1] 1.8	23.4 [6.9] 21.7 [6.4] 1.8	22.6 [6.6] 18.9 [5.5] 1.7
	95 [35]	Total BTUH [kW] Sens BTUH [kW] Power	26.8 [7.9] 17.2 [5.1] 1.9	25.8 [7.6] 14.7 [4.3] 1.8	24.9 [7.3] 12.5 [3.7] 1.8	24.9 [7.3] 21.5 [6.3] 1.9	24.0 [7.0] 18.8 [5.5] 1.8	23.1 [6.8] 16.2 [4.8] 1.8	23.4 [6.9] 23.4 [6.9] 1.9	22.5 [6.6] 21.4 [6.3] 1.9	21.7 [6.4] 18.7 [5.5] 1.8
	100 [37.8]	Total BTUH [kW] Sens BTUH [kW] Power	25.8 [7.6] 16.6 [4.9] 2.0	24.9 [7.3] 14.3 [4.2] 1.9	24.0 [7.0] 12.1 [3.6] 1.9	23.9 [7.0] 20.9 [6.1] 2.0	23.1 [6.8] 18.3 [5.4] 2.0	22.2 [6.5] 15.8 [4.6] 1.9	22.4 [6.6] 22.4 [6.6] 2.0	21.6 [6.3] 20.9 [6.1] 2.0	20.8 [6.1] 18.2 [5.3] 1.9
	105 [40.6]	Total BTUH [kW] Sens BTUH [kW] Power	24.8 [7.3] 16.0 [4.7] 2.1	24.0 [7.0] 13.8 [4.1] 2.1	23.1 [6.8] 11.7 [3.4] 2.0	22.9 [6.7] 20.2 [5.9] 2.1	22.1 [6.5] 17.7 [5.2] 2.1	21.3 [6.2] 15.3 [4.5] 2.0	21.4 [6.3] 21.4 [6.3] 2.1	20.7 [6.1] 20.4 [6.0] 2.0	19.9 [5.8] 17.8 [5.2] 2.0
	110 [43.3]	Total BTUH [kW] Sens BTUH [kW] Power	23.8 [7.0] 15.2 [4.5] 2.2	23.0 [6.7] 13.1 [3.8] 2.2	22.2 [6.5] 11.2 [3.3] 2.1	21.9 [6.4] 19.5 [5.7] 2.2	21.2 [6.2] 17.1 [5.0] 2.2	20.4 [6.0] 14.8 [4.3] 2.1	20.4 [6.0] 20.4 [6.0] 2.2	19.7 [5.8] 19.7 [5.8] 2.2	19.0 [5.6] 17.2 [5.1] 2.1
	115 [46.1]	Total BTUH [kW] Sens BTUH [kW] Power	22.8 [6.7] 14.3 [4.2] 2.3	22.0 [6.4] 12.3 [3.6] 2.3	21.2 [6.2] 10.4 [3.1] 2.2	20.9 [6.1] 18.7 [5.5] 2.3	20.2 [5.9] 16.4 [4.8] 2.3	19.4 [5.7] 14.1 [4.1] 2.3	19.4 [5.7] 19.4 [5.7] 2.3	18.7 [5.5] 18.7 [5.5] 2.3	18.0 [5.3] 16.5 [4.8] 2.3

## GROSS SYSTEMS COOLING PERFORMANCE DATA—TZHH4-A030

		ENTERING INDOOR AIR @ 80°F [26.7°C] dbE ①									
wbE		71°F [21.7°C]			67°F [19.4°C]			63°F [17.2°C]			
CFM [L/s]		1200 [566]	1000 [472]	800 [378]	1200 [566]	1000 [472]	800 [378]	1200 [566]	1000 [472]	800 [378]	
DR ①		.04	.06	.01	.04	.06	.01	.04	.06	.01	
OUTDOOR DRY BULB TEMPERATURE °F [°C]	75 [23.9]	Total BTUH [kW] Sens BTUH [kW] Power	37.9 [11.1] 24.5 [7.2] 1.9	36.6 [10.7] 21.1 [6.2] 1.9	35.3 [10.3] 18.0 [5.3] 1.8	34.9 [10.2] 28.9 [8.5] 1.9	33.7 [9.9] 25.2 [7.4] 1.9	32.4 [9.5] 21.7 [6.4] 1.8	33.0 [9.7] 31.9 [9.4] 1.9	31.9 [9.3] 28.1 [8.2] 1.9	30.7 [9.0] 24.4 [7.2] 1.8
	80 [26.7]	Total BTUH [kW] Sens BTUH [kW] Power	36.9 [10.8] 24.1 [7.1] 2.0	35.6 [10.4] 20.7 [6.1] 2.0	34.3 [10.1] 17.6 [5.2] 1.9	33.9 [9.9] 28.4 [8.3] 2.0	32.7 [9.6] 24.8 [7.3] 2.0	31.5 [9.2] 21.4 [6.3] 1.9	32.0 [9.4] 31.6 [9.3] 2.0	30.9 [9.1] 27.8 [8.2] 2.0	29.8 [8.7] 24.2 [7.1] 1.9
	85 [29.4]	Total BTUH [kW] Sens BTUH [kW] Power	35.9 [10.5] 23.7 [7.0] 2.1	34.6 [10.1] 20.4 [6.0] 2.0	33.4 [9.8] 17.4 [5.1] 2.0	32.8 [9.6] 28.0 [8.2] 2.1	31.7 [9.3] 24.5 [7.2] 2.1	30.5 [8.9] 21.1 [6.2] 2.0	31.0 [9.1] 31.0 [9.1] 2.1	29.9 [8.8] 27.4 [8.0] 2.1	28.8 [8.4] 23.8 [7.0] 2.0
	90 [32.2]	Total BTUH [kW] Sens BTUH [kW] Power	34.8 [10.2] 23.2 [6.8] 2.2	33.5 [9.8] 19.9 [5.8] 2.2	32.3 [9.5] 17.0 [5.0] 2.1	31.7 [9.3] 27.4 [8.0] 2.2	30.6 [9.0] 24.0 [7.0] 2.2	29.5 [8.6] 20.8 [6.1] 2.1	29.8 [8.7] 29.8 [8.7] 2.2	28.8 [8.4] 26.9 [7.9] 2.2	27.7 [8.1] 23.4 [6.9] 2.1
	95 [35]	Total BTUH [kW] Sens BTUH [kW] Power	33.6 [9.8] 22.5 [6.6] 2.3	32.4 [9.5] 19.4 [5.7] 2.3	31.2 [9.1] 16.5 [4.8] 2.2	30.5 [8.9] 26.8 [7.9] 2.3	29.5 [8.6] 23.5 [6.9] 2.3	28.4 [8.3] 20.3 [6.0] 2.2	28.7 [8.4] 28.7 [8.4] 2.3	27.7 [8.1] 26.4 [7.7] 2.3	26.7 [7.8] 23.0 [6.8] 2.2
	100 [37.8]	Total BTUH [kW] Sens BTUH [kW] Power	32.4 [9.5] 21.9 [6.4] 2.4	31.3 [9.2] 18.9 [5.5] 2.4	30.1 [8.8] 16.0 [4.7] 2.3	29.3 [8.6] 26.1 [7.7] 2.4	28.3 [8.3] 22.9 [6.7] 2.4	27.3 [8.0] 19.9 [5.8] 2.3	27.5 [8.1] 27.5 [8.1] 2.4	26.5 [7.8] 25.9 [7.6] 2.4	25.5 [7.5] 22.6 [6.6] 2.3
	105 [40.6]	Total BTUH [kW] Sens BTUH [kW] Power	31.1 [9.1] 21.1 [6.2] 2.6	30.0 [8.8] 18.2 [5.3] 2.5	28.9 [8.5] 15.5 [4.6] 2.5	28.1 [8.2] 25.5 [7.5] 2.6	27.1 [7.9] 22.3 [6.5] 2.5	26.1 [7.6] 19.3 [5.7] 2.5	26.2 [7.7] 26.2 [7.7] 2.6	25.3 [7.4] 25.2 [7.4] 2.5	24.4 [7.2] 22.0 [6.5] 2.5
	110 [43.3]	Total BTUH [kW] Sens BTUH [kW] Power	29.8 [8.7] 20.3 [6.0] 2.7	28.8 [8.4] 17.6 [5.2] 2.6	27.7 [8.1] 15.0 [4.4] 2.6	26.8 [7.9] 24.7 [7.2] 2.7	25.8 [7.6] 21.6 [6.3] 2.6	24.9 [7.3] 18.8 [5.5] 2.6	24.9 [7.3] 24.9 [7.3] 2.7	24.0 [7.0] 24.0 [7.0] 2.6	23.2 [6.8] 21.5 [6.3] 2.6
	115 [46.1]	Total BTUH [kW] Sens BTUH [kW] Power	28.5 [8.4] 19.6 [5.8] 2.8	27.5 [8.1] 16.9 [5.0] 2.8	26.5 [7.8] 14.4 [4.2] 2.7	25.4 [7.4] 23.8 [7.0] 2.8	24.5 [7.2] 20.9 [6.1] 2.8	23.6 [6.9] 18.1 [5.3] 2.7	23.6 [6.9] 23.6 [6.9] 2.8	22.7 [6.7] 22.7 [6.7] 2.8	21.9 [6.4] 20.9 [6.1] 2.7

DR —Depression ratio  
dbE —Entering air dry bulb  
wbE—Entering air wet bulb

Total —Total capacity x 1000 BTUH  
Sens —Sensible capacity x 1000 BTUH  
Power—KW input

NOTES: ① When the entering air dry bulb is other than 80°F [27°C], adjust the sensible capacity from the table by adding  $[1.10 \times \text{CFM} \times (1 - \text{DR}) \times (\text{dbE} - 80)]$ .

[ ] Designates Metric Conversions



## GROSS SYSTEMS COOLING PERFORMANCE DATA—TZHH4-A036

		ENTERING INDOOR AIR @ 80°F [26.7°C] dbE ①									
wbE		71°F [21.7°C]			67°F [19.4°C]			63°F [17.2°C]			
CFM [L/s]		1440 [680]	1200 [566]	960 [453]	1440 [680]	1200 [566]	960 [453]	1440 [680]	1200 [566]	960 [453]	
DR ①		.04	.07	.10	.04	.07	.10	.04	.07	.10	
OUTDOOR DRY BULB TEMPERATURE °F [°C]	75 [23.9]	Total BTUH [kW] Sens BTUH [kW] Power	45.3 [13.3] 28.5 [8.4] 2.4	43.7 [12.8] 24.5 [7.2] 2.4	42.1 [12.3] 20.8 [6.1] 2.3	42.5 [12.5] 34.4 [10.1] 2.4	41.0 [12.0] 30.0 [8.8] 2.3	39.5 [11.6] 25.8 [7.6] 2.3	39.7 [11.6] 37.7 [11.1] 2.4	38.3 [11.2] 33.1 [9.7] 2.3	36.9 [10.8] 28.7 [8.4] 2.3
	80 [26.7]	Total BTUH [kW] Sens BTUH [kW] Power	44.1 [12.9] 28.1 [8.2] 2.5	42.5 [12.5] 24.1 [7.1] 2.5	41.0 [12.0] 20.5 [6.0] 2.4	41.3 [12.1] 34.1 [10.0] 2.5	39.9 [11.7] 29.8 [8.7] 2.5	38.4 [11.3] 25.7 [7.5] 2.4	38.4 [11.3] 37.3 [10.9] 2.5	37.1 [10.9] 32.8 [9.6] 2.4	35.7 [10.5] 28.5 [8.4] 2.4
	85 [29.4]	Total BTUH [kW] Sens BTUH [kW] Power	42.8 [12.5] 27.6 [8.1] 2.6	41.3 [12.1] 23.7 [7.0] 2.6	39.8 [11.7] 20.1 [5.9] 2.6	40.0 [11.7] 33.6 [9.9] 2.6	38.6 [11.3] 29.3 [8.6] 2.6	37.2 [10.9] 25.3 [7.4] 2.5	37.2 [10.9] 36.8 [10.8] 2.6	35.9 [10.5] 32.4 [9.5] 2.6	34.6 [10.1] 28.2 [8.3] 2.5
	90 [32.2]	Total BTUH [kW] Sens BTUH [kW] Power	41.5 [12.2] 27.0 [7.9] 2.8	40.0 [11.7] 23.2 [6.8] 2.7	38.6 [11.3] 19.8 [5.8] 2.7	38.7 [11.3] 33.0 [9.7] 2.8	37.4 [11.0] 28.9 [8.5] 2.7	36.0 [10.6] 24.9 [7.3] 2.7	35.8 [10.5] 35.8 [10.5] 2.8	34.6 [10.1] 31.8 [9.3] 2.7	33.3 [9.8] 27.7 [8.1] 2.7
	95 [35]	Total BTUH [kW] Sens BTUH [kW] Power	40.1 [11.8] 26.2 [7.7] 2.9	38.7 [11.3] 22.6 [6.6] 2.9	37.3 [10.9] 19.2 [5.6] 2.8	37.3 [10.9] 32.3 [9.5] 2.9	36.0 [10.6] 28.2 [8.3] 2.9	34.7 [10.2] 24.4 [7.2] 2.8	34.5 [10.1] 34.5 [10.1] 2.9	33.3 [9.8] 31.3 [9.2] 2.8	32.1 [9.4] 27.3 [8.0] 2.8
	100 [37.8]	Total BTUH [kW] Sens BTUH [kW] Power	38.7 [11.3] 25.5 [7.5] 3.1	37.4 [11.0] 22.0 [6.5] 3.0	36.0 [10.6] 18.7 [5.5] 3.0	35.9 [10.5] 31.5 [9.2] 3.1	34.7 [10.2] 27.6 [8.1] 3.0	33.4 [9.8] 23.8 [7.0] 3.0	33.1 [9.7] 33.1 [9.7] 3.1	31.9 [9.3] 30.6 [9.0] 3.0	30.7 [9.0] 26.7 [7.8] 2.9
	105 [40.6]	Total BTUH [kW] Sens BTUH [kW] Power	37.2 [10.9] 24.6 [7.2] 3.3	35.9 [10.5] 21.2 [6.2] 3.2	34.6 [10.1] 18.0 [5.3] 3.1	34.5 [10.1] 30.6 [9.0] 3.2	33.2 [9.7] 26.7 [7.8] 3.2	32.0 [9.4] 23.1 [6.8] 3.1	31.6 [9.3] 31.6 [9.3] 3.2	30.5 [8.9] 29.8 [8.7] 3.2	29.4 [8.6] 26.0 [7.6] 3.1
	110 [43.3]	Total BTUH [kW] Sens BTUH [kW] Power	35.7 [10.5] 23.5 [6.9] 3.4	34.5 [10.1] 20.3 [6.0] 3.4	33.2 [9.7] 17.2 [5.1] 3.3	32.9 [9.6] 29.5 [8.7] 3.4	31.8 [9.3] 25.9 [7.6] 3.3	30.6 [9.0] 22.4 [6.6] 3.3	30.1 [8.8] 30.1 [8.8] 3.4	29.0 [8.5] 28.9 [8.5] 3.3	28.0 [8.2] 25.3 [7.4] 3.3
	115 [46.1]	Total BTUH [kW] Sens BTUH [kW] Power	34.2 [10.0] 22.5 [6.6] 3.6	33.0 [9.7] 19.4 [5.7] 3.5	31.8 [9.3] 16.5 [4.8] 3.5	31.4 [9.2] 28.5 [8.4] 3.6	30.3 [8.9] 25.0 [7.3] 3.5	29.2 [8.6] 21.7 [6.4] 3.5	28.5 [8.4] 28.5 [8.4] 3.6	27.5 [8.1] 27.5 [8.1] 3.5	26.5 [7.8] 24.4 [7.2] 3.4

## GROSS SYSTEMS COOLING PERFORMANCE DATA—TZHH4-A037

		ENTERING INDOOR AIR @ 80°F [26.7°C] dbE ①									
wbE		71°F [21.7°C]			67°F [19.4°C]			63°F [17.2°C]			
CFM [L/s]		1440 [680]	1250 [590]	960 [453]	1440 [680]	1250 [590]	960 [453]	1440 [680]	1250 [590]	960 [453]	
DR ①		.10	.12	.16	.10	.12	.16	.10	.12	.16	
OUTDOOR DRY BULB TEMPERATURE °F [°C]	75 [23.9]	Total BTUH [kW] Sens BTUH [kW] Power	45.0 [13.2] 28.8 [8.5] 2.2	43.8 [12.8] 25.7 [7.5] 2.2	42.0 [12.3] 21.3 [6.3] 2.2	42.9 [12.6] 33.9 [9.9] 2.2	41.7 [12.2] 30.5 [8.9] 2.2	40.0 [11.7] 25.7 [7.5] 2.1	41.0 [12.0] 37.6 [11.0] 2.2	39.9 [11.7] 34.0 [10.0] 2.2	38.2 [11.2] 28.8 [8.5] 2.1
	80 [26.7]	Total BTUH [kW] Sens BTUH [kW] Power	43.7 [12.8] 28.2 [8.3] 2.4	42.5 [12.5] 25.1 [7.4] 2.3	40.7 [11.9] 20.8 [6.1] 2.3	41.6 [12.2] 33.2 [9.7] 2.3	40.5 [11.9] 29.9 [8.8] 2.3	38.8 [11.4] 25.1 [7.4] 2.3	39.7 [11.6] 36.9 [10.8] 2.3	38.6 [11.3] 33.4 [9.8] 2.3	37.0 [10.8] 28.4 [8.3] 2.2
	85 [29.4]	Total BTUH [kW] Sens BTUH [kW] Power	42.3 [12.4] 27.4 [8.0] 2.5	41.2 [12.1] 24.5 [7.2] 2.5	39.4 [11.5] 20.2 [5.9] 2.4	40.2 [11.8] 32.6 [9.6] 2.5	39.1 [11.5] 29.3 [8.6] 2.4	37.4 [11.0] 24.6 [7.2] 2.4	38.3 [11.2] 36.3 [10.6] 2.4	37.2 [10.9] 32.8 [9.6] 2.4	35.7 [10.5] 27.9 [8.2] 2.4
	90 [32.2]	Total BTUH [kW] Sens BTUH [kW] Power	40.8 [12.0] 26.7 [7.8] 2.6	39.7 [11.6] 23.8 [7.0] 2.6	38.0 [11.1] 19.7 [5.8] 2.5	38.7 [11.3] 31.8 [9.3] 2.6	37.6 [11.0] 28.6 [8.4] 2.6	36.0 [10.6] 24.1 [7.1] 2.5	36.8 [10.8] 35.6 [10.4] 2.6	35.8 [10.5] 32.2 [9.4] 2.6	34.3 [10.1] 27.4 [8.0] 2.5
	95 [35]	Total BTUH [kW] Sens BTUH [kW] Power	39.2 [11.5] 25.9 [7.6] 2.8	38.2 [11.2] 23.2 [6.8] 2.8	36.5 [10.7] 19.2 [5.6] 2.7	37.1 [10.9] 31.0 [9.1] 2.8	36.1 [10.6] 27.9 [8.2] 2.7	34.6 [10.1] 23.5 [6.9] 2.7	35.2 [10.3] 34.7 [10.2] 2.7	34.2 [10.0] 31.4 [9.2] 2.7	32.8 [9.6] 26.8 [7.9] 2.7
	100 [37.8]	Total BTUH [kW] Sens BTUH [kW] Power	37.5 [11.0] 25.1 [7.4] 3.0	36.5 [10.7] 22.4 [6.6] 2.9	35.0 [10.3] 18.6 [5.5] 2.9	35.4 [10.4] 30.2 [8.9] 2.9	34.4 [10.1] 27.2 [8.0] 2.9	33.0 [9.7] 23.0 [6.8] 2.8	33.5 [9.8] 33.5 [9.8] 2.9	32.6 [9.6] 30.7 [9.0] 2.9	31.2 [9.1] 26.1 [7.7] 2.8
	105 [40.6]	Total BTUH [kW] Sens BTUH [kW] Power	35.7 [10.5] 24.2 [7.1] 3.1	34.8 [10.2] 21.7 [6.4] 3.1	33.3 [9.8] 18.0 [5.3] 3.0	33.6 [9.8] 29.2 [8.6] 3.1	32.7 [9.6] 26.4 [7.7] 3.1	31.3 [9.2] 22.3 [6.5] 3.0	31.7 [9.3] 31.7 [9.3] 3.1	30.8 [9.0] 29.9 [8.8] 3.0	29.5 [8.6] 25.5 [7.5] 3.0
	110 [43.3]	Total BTUH [kW] Sens BTUH [kW] Power	33.9 [9.9] 23.3 [6.8] 3.3	33.0 [9.7] 20.9 [6.1] 3.3	31.6 [9.3] 17.4 [5.1] 3.2	31.8 [9.3] 28.5 [8.4] 3.3	30.9 [9.1] 25.7 [7.5] 3.2	29.6 [8.7] 21.8 [6.4] 3.2	29.8 [8.7] 29.8 [8.7] 3.3	29.0 [8.5] 29.0 [8.5] 3.2	27.8 [8.1] 24.9 [7.3] 3.2
	115 [46.1]	Total BTUH [kW] Sens BTUH [kW] Power	31.9 [9.3] 22.4 [6.6] 3.5	31.1 [9.1] 20.1 [5.9] 3.5	29.7 [8.7] 16.7 [4.9] 3.4	29.8 [8.7] 27.4 [8.0] 3.5	29.0 [8.5] 24.8 [7.3] 3.4	27.8 [8.1] 21.0 [6.2] 3.4	27.9 [8.2] 27.9 [8.2] 3.5	27.1 [7.9] 27.1 [8.0] 3.4	26.0 [7.6] 24.3 [7.1] 3.3

DR —Depression ratio  
dbE —Entering air dry bulb  
wbE—Entering air wet bulb

Total —Total capacity x 1000 BTUH  
Sens —Sensible capacity x 1000 BTUH  
Power —kW input

NOTES: ① When the entering air dry bulb is other than 80°F [27°C], adjust the sensible capacity from the table by adding  $[1.10 \times \text{CFM} \times (1 - \text{DR}) \times (\text{dbE} - 80)]$ .

[ ] Designates Metric Conversions

## GROSS SYSTEMS COOLING PERFORMANCE DATA—TZHH4-042

		ENTERING INDOOR AIR @ 80°F [26.7°C] dbE ①									
wbE		71°F [21.7°C]			67°F [19.4°C]			63°F [17.2°C]			
CFM [L/s]		1740 [821]	1450 [684]	1160 [547]	1740 [821]	1450 [684]	1160 [547]	1740 [821]	1450 [684]	1160 [547]	
DR ①		.11	.15	.19	.11	.15	.19	.11	.15	.19	
OUTDOOR DRY BULB TEMPERATURE °F [°C]	75 [23.9]	Total BTUH [kW] Sens BTUH [kW] Power	52.6 [15.4] 31.8 [9.3] 2.8	50.7 [14.9] 27.2 [8.0] 2.7	48.9 [14.3] 23.0 [6.8] 2.7	50.5 [14.8] 39.3 [11.5] 2.8	48.7 [14.3] 34.1 [10.0] 2.7	47.0 [13.8] 29.4 [8.6] 2.7	47.1 [13.8] 42.9 [12.6] 2.7	45.5 [13.3] 37.6 [11.0] 2.7	43.8 [12.8] 32.5 [9.5] 2.6
	80 [26.7]	Total BTUH [kW] Sens BTUH [kW] Power	51.4 [15.1] 31.5 [9.2] 2.9	49.6 [14.5] 27.0 [7.9] 2.9	47.8 [14.0] 22.8 [6.7] 2.8	49.4 [14.5] 39.0 [11.4] 2.9	47.6 [14.0] 33.9 [9.9] 2.9	45.9 [13.5] 29.2 [8.6] 2.8	46.0 [13.5] 42.7 [12.5] 2.9	44.4 [13.0] 37.5 [11.0] 2.8	42.8 [12.5] 32.5 [9.5] 2.8
	85 [29.4]	Total BTUH [kW] Sens BTUH [kW] Power	50.2 [14.7] 31.1 [9.1] 3.1	48.4 [14.2] 26.6 [7.8] 3.0	46.7 [13.7] 22.6 [6.6] 3.0	48.1 [14.1] 38.6 [11.3] 3.1	46.5 [13.6] 33.7 [9.9] 3.0	44.8 [13.1] 29.0 [8.5] 3.0	44.8 [13.1] 42.3 [12.4] 3.1	43.2 [12.7] 37.1 [10.9] 3.0	41.6 [12.2] 32.2 [9.4] 3.0
	90 [32.2]	Total BTUH [kW] Sens BTUH [kW] Power	48.9 [14.3] 30.6 [9.0] 3.3	47.2 [13.8] 26.3 [7.7] 3.2	45.5 [13.3] 22.3 [6.5] 3.2	46.8 [13.7] 38.0 [11.1] 3.3	45.2 [13.2] 33.2 [9.7] 3.2	43.5 [12.7] 28.6 [8.4] 3.1	43.5 [12.7] 41.8 [12.3] 3.2	41.9 [12.3] 36.6 [10.7] 3.2	40.4 [11.8] 31.8 [9.3] 3.1
	95 [35]	Total BTUH [kW] Sens BTUH [kW] Power	47.5 [13.9] 29.8 [8.7] 3.5	45.8 [13.4] 25.6 [7.5] 3.4	44.1 [12.9] 21.7 [6.4] 3.3	45.4 [13.3] 37.4 [11.0] 3.4	43.8 [12.8] 32.6 [9.6] 3.4	42.2 [12.4] 28.1 [8.2] 3.3	42.1 [12.3] 41.1 [12.1] 3.4	40.6 [11.9] 36.1 [10.6] 3.4	39.1 [11.5] 31.4 [9.2] 3.3
	100 [37.8]	Total BTUH [kW] Sens BTUH [kW] Power	46.0 [13.5] 29.1 [8.5] 3.7	44.4 [13.0] 25.0 [7.3] 3.6	42.7 [12.5] 21.1 [6.2] 3.5	43.9 [12.9] 36.5 [10.7] 3.6	42.4 [12.4] 31.9 [9.4] 3.6	40.8 [12.0] 27.5 [8.1] 3.5	40.6 [11.9] 40.3 [11.8] 3.6	39.1 [11.5] 35.4 [10.4] 3.6	37.7 [11.0] 30.8 [9.0] 3.5
	105 [40.6]	Total BTUH [kW] Sens BTUH [kW] Power	44.4 [13.0] 28.1 [8.2] 3.9	42.8 [12.5] 24.1 [7.1] 3.8	41.3 [12.1] 20.5 [6.0] 3.7	42.3 [12.4] 35.5 [10.4] 3.9	40.8 [12.0] 31.0 [9.1] 3.8	39.3 [11.5] 26.7 [7.8] 3.7	38.9 [11.4] 38.9 [11.4] 3.8	37.6 [11.0] 34.6 [10.2] 3.8	36.2 [10.6] 30.1 [8.8] 3.7
	110 [43.3]	Total BTUH [kW] Sens BTUH [kW] Power	42.7 [12.5] 26.9 [7.9] 4.1	41.2 [12.1] 23.1 [6.8] 4.0	39.7 [11.6] 19.6 [5.8] 4.0	40.6 [11.9] 34.4 [10.1] 4.1	39.2 [11.5] 30.1 [8.8] 4.0	37.8 [11.1] 26.0 [7.6] 3.9	37.3 [10.9] 37.3 [10.9] 4.1	35.9 [10.5] 33.5 [9.8] 4.0	34.6 [10.1] 29.2 [8.6] 3.9
	115 [46.1]	Total BTUH [kW] Sens BTUH [kW] Power	40.9 [12.0] 25.7 [7.5] 4.3	39.4 [11.5] 22.0 [6.5] 4.3	38.0 [11.1] 18.7 [5.5] 4.2	38.8 [11.4] 33.1 [9.7] 4.3	37.5 [11.0] 29.0 [8.5] 4.2	36.1 [10.6] 25.0 [7.3] 4.2	35.5 [10.4] 35.5 [10.4] 4.3	34.2 [10.0] 32.4 [9.5] 4.2	33.0 [9.7] 28.3 [8.3] 4.1

## GROSS SYSTEMS COOLING PERFORMANCE DATA—TZHH4-A043

		ENTERING INDOOR AIR @ 80°F [26.7°C] dbE ①									
wbE		71°F [21.7°C]			67°F [19.4°C]			63°F [17.2°C]			
CFM [L/s]		1740 [821]	1425 [672]	1160 [547]	1740 [821]	1425 [672]	1160 [547]	1740 [821]	1425 [672]	1160 [547]	
DR ①		.05	.09	.12	.05	.09	.12	.05	.09	.12	
OUTDOOR DRY BULB TEMPERATURE °F [°C]	75 [23.9]	Total BTUH [kW] Sens BTUH [kW] Power	54.5 [16.0] 35.9 [10.5] 2.6	52.4 [15.4] 30.4 [8.9] 2.6	50.6 [14.8] 26.1 [7.7] 2.6	51.3 [15.0] 41.9 [12.3] 2.6	49.3 [14.4] 36.0 [10.6] 2.6	47.7 [14.0] 31.4 [9.2] 2.5	48.5 [14.2] 46.4 [13.6] 2.6	46.6 [13.7] 40.2 [11.8] 2.6	45.1 [13.2] 35.3 [10.4] 2.5
	80 [26.7]	Total BTUH [kW] Sens BTUH [kW] Power	52.9 [15.5] 35.0 [10.3] 2.8	50.8 [14.9] 29.6 [8.7] 2.7	49.1 [14.4] 25.5 [7.5] 2.7	49.7 [14.6] 41.1 [12.1] 2.8	47.8 [14.0] 35.4 [10.4] 2.7	46.2 [13.5] 30.9 [9.1] 2.7	46.9 [13.7] 45.6 [13.4] 2.7	45.1 [13.2] 39.5 [11.6] 2.7	43.6 [12.8] 34.7 [10.2] 2.6
	85 [29.4]	Total BTUH [kW] Sens BTUH [kW] Power	51.3 [15.0] 34.2 [10.0] 2.9	49.3 [14.4] 29.0 [8.5] 2.9	47.7 [14.0] 25.0 [7.3] 2.8	48.2 [14.1] 40.4 [11.9] 2.9	46.3 [13.6] 34.7 [10.2] 2.9	44.7 [13.1] 30.2 [8.9] 2.8	45.4 [13.3] 44.8 [13.1] 2.9	43.6 [12.8] 38.8 [11.4] 2.8	42.1 [12.3] 34.1 [10.0] 2.8
	90 [32.2]	Total BTUH [kW] Sens BTUH [kW] Power	49.8 [14.6] 33.4 [9.8] 3.1	47.8 [14.0] 28.3 [8.3] 3.0	46.2 [13.5] 24.4 [7.2] 3.0	46.6 [13.7] 39.5 [11.6] 3.1	44.8 [13.1] 34.0 [10.0] 3.0	43.3 [12.7] 29.7 [8.7] 3.0	43.8 [12.8] 43.8 [12.8] 3.1	42.1 [12.3] 38.2 [11.2] 3.0	40.7 [11.9] 33.6 [9.9] 3.0
	95 [35]	Total BTUH [kW] Sens BTUH [kW] Power	48.2 [14.1] 32.5 [9.5] 3.3	46.3 [13.6] 27.6 [8.1] 3.2	44.8 [13.1] 23.8 [7.0] 3.2	45.1 [13.2] 38.7 [11.4] 3.3	43.3 [12.7] 33.3 [9.8] 3.2	41.8 [12.3] 29.0 [8.5] 3.1	42.2 [12.4] 42.2 [12.4] 3.2	40.6 [11.9] 37.4 [11.0] 3.2	39.2 [11.5] 32.9 [9.7] 3.1
	100 [37.8]	Total BTUH [kW] Sens BTUH [kW] Power	46.7 [13.7] 31.7 [9.3] 3.5	44.9 [13.2] 26.9 [7.9] 3.4	43.3 [12.7] 23.1 [6.8] 3.4	43.5 [12.7] 37.8 [11.1] 3.5	41.8 [12.3] 32.6 [9.6] 3.4	40.4 [11.8] 28.5 [8.4] 3.3	40.7 [11.9] 40.7 [11.9] 3.4	39.1 [11.5] 36.7 [10.8] 3.4	37.8 [11.1] 32.3 [9.5] 3.3
	105 [40.6]	Total BTUH [kW] Sens BTUH [kW] Power	45.1 [13.2] 30.8 [9.0] 3.7	43.4 [12.7] 26.2 [7.7] 3.6	41.9 [12.3] 22.6 [6.6] 3.5	42.0 [12.3] 37.0 [10.9] 3.7	40.3 [11.8] 31.8 [9.3] 3.6	39.0 [11.4] 27.9 [8.2] 3.5	39.2 [11.5] 39.2 [11.5] 3.6	37.6 [11.0] 36.0 [10.6] 3.6	36.4 [10.7] 31.8 [9.3] 3.5
	110 [43.3]	Total BTUH [kW] Sens BTUH [kW] Power	43.6 [12.8] 29.9 [8.8] 3.9	41.9 [12.3] 25.4 [7.5] 3.8	40.5 [11.9] 21.9 [6.4] 3.7	40.4 [11.8] 36.1 [10.6] 3.9	38.9 [11.4] 31.2 [9.2] 3.8	37.6 [11.0] 27.3 [8.0] 3.7	37.6 [11.0] 37.6 [11.0] 3.8	36.2 [10.6] 35.3 [10.4] 3.8	35.0 [10.3] 31.1 [9.1] 3.7
	115 [46.1]	Total BTUH [kW] Sens BTUH [kW] Power	42.1 [12.3] 29.0 [8.5] 4.1	40.4 [11.8] 24.6 [7.2] 4.0	39.1 [11.5] 21.3 [6.3] 4.0	38.9 [11.4] 35.2 [10.3] 4.1	37.4 [11.0] 30.4 [8.9] 4.0	36.1 [10.6] 26.6 [7.8] 3.9	36.1 [10.6] 36.1 [10.6] 4.1	34.7 [10.2] 34.5 [10.1] 4.0	33.5 [9.8] 30.4 [8.9] 3.9

DR —Depression ratio  
dbE —Entering air dry bulb  
wbE—Entering air wet bulb

Total —Total capacity x 1000 BTUH  
Sens —Sensible capacity x 1000 BTUH  
Power—KW input

NOTES: ① When the entering air dry bulb is other than 80°F [27°C], adjust the sensible capacity from the table by adding  $[1.10 \times \text{CFM} \times (1 - \text{DR}) \times (\text{dbE} - 80)]$ .

[ ] Designates Metric Conversions

## GROSS SYSTEMS COOLING PERFORMANCE DATA—TZHH4-A048

		ENTERING INDOOR AIR @ 80°F [26.7°C] dbE ①									
wbE		71°F [21.7°C]			67°F [19.4°C]			63°F [17.2°C]			
CFM [L/s]		1860 [878]	1550 [732]	1240 [585]	1860 [878]	1550 [732]	1240 [585]	1860 [878]	1550 [732]	1240 [585]	
DR ①		.01	.05	.09	.01	.05	.09	.01	.05	.09	
OUTDOOR DRY BULB TEMPERATURE °F [°C]	75 [23.9]	Total BTUH [kW] Sens BTUH [kW] Power	60.4 [17.7] 38.0 [11.1] 3.1	58.3 [17.1] 32.7 [9.6] 3.0	56.1 [16.4] 27.7 [8.1] 3.0	57.1 [16.7] 45.7 [13.4] 3.1	55.1 [16.1] 39.8 [11.7] 3.0	53.1 [15.6] 34.3 [10.1] 3.0	52.9 [15.5] 49.4 [14.5] 3.1	51.1 [15.0] 43.4 [12.7] 3.0	49.2 [14.4] 37.6 [11.0] 3.0
	80 [26.7]	Total BTUH [kW] Sens BTUH [kW] Power	58.9 [17.3] 37.6 [11.0] 3.3	56.8 [16.6] 32.3 [9.5] 3.2	54.8 [16.1] 27.5 [8.1] 3.2	55.6 [16.3] 45.4 [13.3] 3.3	53.7 [15.7] 39.6 [11.6] 3.2	51.7 [15.2] 34.1 [10.0] 3.1	51.4 [15.1] 49.0 [14.4] 3.2	49.6 [14.5] 43.0 [12.6] 3.2	47.8 [14.0] 37.4 [11.0] 3.1
	85 [29.4]	Total BTUH [kW] Sens BTUH [kW] Power	57.3 [16.8] 37.0 [10.9] 3.5	55.3 [16.2] 31.8 [9.3] 3.4	53.3 [15.6] 27.0 [7.9] 3.3	54.1 [15.9] 44.8 [13.1] 3.4	52.2 [15.3] 39.1 [11.5] 3.4	50.3 [14.7] 33.7 [9.9] 3.3	49.9 [14.6] 48.4 [14.2] 3.4	48.1 [14.1] 42.5 [12.5] 3.4	46.4 [13.6] 37.0 [10.9] 3.3
	90 [32.2]	Total BTUH [kW] Sens BTUH [kW] Power	55.7 [16.3] 36.3 [10.6] 3.7	53.7 [15.7] 31.2 [9.2] 3.6	51.8 [15.2] 26.6 [7.8] 3.5	52.4 [15.4] 44.1 [12.9] 3.6	50.6 [14.8] 38.5 [11.3] 3.6	48.7 [14.3] 33.2 [9.7] 3.5	48.2 [14.1] 47.7 [14.0] 3.6	46.5 [13.6] 41.9 [12.3] 3.6	44.8 [13.1] 36.4 [10.7] 3.5
	95 [35]	Total BTUH [kW] Sens BTUH [kW] Power	54.0 [15.8] 35.4 [10.4] 3.9	52.1 [15.3] 30.5 [8.9] 3.8	50.2 [14.7] 25.9 [7.6] 3.7	50.7 [14.9] 43.2 [12.7] 3.9	49.0 [14.4] 37.8 [11.1] 3.8	47.2 [13.8] 32.6 [9.6] 3.7	46.5 [13.6] 46.5 [13.6] 3.8	44.9 [13.2] 41.2 [12.1] 3.8	43.3 [12.7] 35.9 [10.5] 3.7
	100 [37.8]	Total BTUH [kW] Sens BTUH [kW] Power	52.2 [15.3] 34.3 [10.1] 4.1	50.4 [14.8] 29.6 [8.7] 4.0	48.6 [14.2] 25.2 [7.4] 3.9	49.0 [14.4] 42.2 [12.4] 4.1	47.3 [13.9] 36.9 [10.8] 4.0	45.5 [13.3] 31.8 [9.3] 3.9	44.8 [13.1] 44.8 [13.1] 4.1	43.2 [12.7] 40.3 [11.8] 4.0	41.6 [12.2] 35.1 [10.3] 3.9
	105 [40.6]	Total BTUH [kW] Sens BTUH [kW] Power	50.4 [14.8] 33.2 [9.7] 4.3	48.7 [14.3] 28.7 [8.4] 4.2	46.9 [13.7] 24.4 [7.2] 4.2	47.2 [13.8] 41.1 [12.1] 4.3	45.5 [13.3] 35.9 [10.5] 4.2	43.8 [12.8] 31.0 [9.1] 4.2	43.0 [12.6] 43.0 [12.6] 4.3	41.5 [12.2] 39.4 [11.6] 4.2	39.9 [11.7] 34.3 [10.1] 4.2
	110 [43.3]	Total BTUH [kW] Sens BTUH [kW] Power	48.5 [14.2] 31.8 [9.3] 4.6	46.8 [13.7] 27.4 [8.0] 4.5	45.1 [13.2] 23.3 [6.8] 4.4	45.3 [13.3] 39.7 [11.6] 4.6	43.7 [12.8] 34.7 [10.2] 4.5	42.1 [12.3] 30.0 [8.8] 4.4	41.1 [12.0] 41.1 [12.1] 4.5	39.6 [11.6] 38.2 [11.2] 4.5	38.2 [11.2] 33.4 [9.8] 4.4
	115 [46.1]	Total BTUH [kW] Sens BTUH [kW] Power	46.6 [13.7] 30.4 [8.9] 4.8	45.0 [13.2] 26.2 [7.7] 4.7	43.3 [12.7] 22.2 [6.5] 4.7	43.3 [12.7] 38.2 [11.2] 4.8	41.8 [12.3] 33.4 [9.8] 4.7	40.3 [11.8] 28.9 [8.5] 4.6	39.1 [11.5] 39.1 [11.5] 4.8	37.7 [11.0] 36.8 [10.8] 4.7	36.4 [10.7] 32.2 [9.4] 4.6

## GROSS SYSTEMS COOLING PERFORMANCE DATA—TZHH4-A049

		ENTERING INDOOR AIR @ 80°F [26.7°C] dbE ①									
wbE		71°F [21.7°C]			67°F [19.4°C]			63°F [17.2°C]			
CFM [L/s]		1860 [878]	1525 [720]	1240 [585]	1860 [878]	1525 [720]	1240 [585]	1860 [878]	1525 [720]	1240 [585]	
DR ①		.08	.13	.18	.08	.13	.18	.08	.13	.18	
OUTDOOR DRY BULB TEMPERATURE °F [°C]	75 [23.9]	Total BTUH [kW] Sens BTUH [kW] Power	60.3 [17.7] 37.9 [11.1] 3.1	58.0 [17.0] 32.1 [9.4] 3.0	56.0 [16.4] 27.5 [8.1] 3.0	57.4 [16.8] 44.5 [13.1] 3.0	55.2 [16.2] 38.2 [11.2] 3.0	53.3 [15.6] 33.1 [9.7] 2.9	54.6 [16.0] 50.3 [14.8] 3.0	52.5 [15.4] 43.5 [12.8] 3.0	50.7 [14.9] 38.1 [11.2] 2.9
	80 [26.7]	Total BTUH [kW] Sens BTUH [kW] Power	59.0 [17.3] 37.4 [11.0] 3.3	56.7 [16.6] 31.6 [9.3] 3.2	54.8 [16.1] 27.1 [8.0] 3.1	56.0 [16.4] 43.9 [12.9] 3.2	53.9 [15.8] 37.7 [11.1] 3.2	52.0 [15.2] 32.7 [9.6] 3.1	53.2 [15.6] 49.6 [14.5] 3.2	51.2 [15.0] 43.0 [12.6] 3.1	49.4 [14.5] 37.6 [11.0] 3.1
	85 [29.4]	Total BTUH [kW] Sens BTUH [kW] Power	57.4 [16.8] 36.6 [10.7] 3.4	55.2 [16.2] 31.0 [9.1] 3.4	53.3 [15.6] 26.6 [7.8] 3.3	54.5 [16.0] 43.2 [12.7] 3.4	52.4 [15.4] 37.1 [10.9] 3.3	50.6 [14.8] 32.2 [9.4] 3.3	51.7 [15.2] 49.0 [14.4] 3.4	49.7 [14.6] 42.4 [12.4] 3.3	48.0 [14.1] 37.2 [10.9] 3.3
	90 [32.2]	Total BTUH [kW] Sens BTUH [kW] Power	55.7 [16.3] 35.7 [10.5] 3.6	53.6 [15.7] 30.3 [8.9] 3.6	51.8 [15.2] 26.0 [7.6] 3.5	52.8 [15.5] 42.3 [12.4] 3.6	50.8 [14.9] 36.4 [10.7] 3.5	49.0 [14.4] 31.6 [9.3] 3.5	50.0 [14.7] 48.1 [14.1] 3.6	48.0 [14.1] 41.6 [12.2] 3.5	46.4 [13.6] 36.5 [10.7] 3.4
	95 [35]	Total BTUH [kW] Sens BTUH [kW] Power	53.9 [15.8] 34.9 [10.2] 3.8	51.8 [15.2] 29.6 [8.7] 3.8	50.0 [14.7] 25.4 [7.5] 3.7	50.9 [14.9] 41.5 [12.2] 3.8	49.0 [14.4] 35.7 [10.5] 3.7	47.3 [13.9] 31.0 [9.1] 3.7	48.1 [14.1] 47.2 [13.8] 3.8	46.3 [13.6] 41.0 [12.0] 3.7	44.7 [13.1] 36.0 [10.6] 3.6
	100 [37.8]	Total BTUH [kW] Sens BTUH [kW] Power	51.8 [15.2] 34.0 [10.0] 4.0	49.8 [14.6] 28.8 [8.5] 4.0	48.1 [14.1] 24.7 [7.2] 3.9	48.9 [14.3] 40.6 [11.9] 4.0	47.0 [13.8] 34.9 [10.2] 3.9	45.4 [13.3] 30.4 [8.9] 3.9	46.1 [13.5] 46.1 [13.5] 4.0	44.3 [13.0] 40.2 [11.8] 3.9	42.8 [12.5] 35.3 [10.4] 3.8
	105 [40.6]	Total BTUH [kW] Sens BTUH [kW] Power	49.6 [14.5] 33.0 [9.7] 4.3	47.7 [14.0] 28.0 [8.2] 4.2	46.1 [13.5] 24.1 [7.1] 4.1	46.7 [13.7] 39.6 [11.6] 4.2	44.9 [13.2] 34.1 [10.0] 4.2	43.4 [12.7] 29.8 [8.7] 4.1	43.9 [12.9] 43.9 [12.9] 4.2	42.2 [12.4] 39.4 [11.6] 4.1	40.8 [12.0] 34.7 [10.2] 4.1
	110 [43.3]	Total BTUH [kW] Sens BTUH [kW] Power	47.3 [13.9] 32.0 [9.4] 4.5	45.4 [13.3] 27.1 [8.0] 4.4	43.9 [12.9] 23.4 [6.9] 4.3	44.3 [13.0] 38.4 [11.3] 4.5	42.6 [12.5] 33.1 [9.7] 4.4	41.2 [12.1] 28.9 [8.5] 4.3	41.5 [12.2] 41.5 [12.2] 4.4	39.9 [11.7] 38.5 [11.3] 4.3	38.6 [11.3] 34.0 [10.0] 4.3
	115 [46.1]	Total BTUH [kW] Sens BTUH [kW] Power	44.7 [13.1] 30.7 [9.0] 4.7	43.0 [12.6] 26.1 [7.7] 4.6	41.6 [12.2] 22.5 [6.6] 4.6	41.8 [12.3] 37.3 [10.9] 4.7	40.2 [11.8] 32.2 [9.4] 4.6	38.8 [11.4] 28.1 [8.2] 4.5	39.0 [11.4] 39.0 [11.4] 4.7	37.5 [11.0] 37.5 [11.0] 4.6	36.2 [10.6] 33.0 [9.7] 4.5

DR —Depression ratio  
dbE —Entering air dry bulb  
wbE—Entering air wet bulb

Total —Total capacity x 1000 BTUH  
Sens —Sensible capacity x 1000 BTUH  
Power —kW input

NOTES: ① When the entering air dry bulb is other than 80°F [27°C], adjust the sensible capacity from the table by adding  $[1.10 \times \text{CFM} \times (1 - \text{DR}) \times (\text{dbE} - 80)]$ .

[ ] Designates Metric Conversions

## GROSS SYSTEMS COOLING PERFORMANCE DATA—TZHH4-A060

ENTERING INDOOR AIR @ 80°F [26.7°C] dbE ①											
wbE		71°F [21.7°C]			67°F [19.4°C]			63°F [17.2°C]			
CFM [L/s]		2280 [1076]	1900 [897]	1520 [717]	2280 [1076]	1900 [897]	1520 [717]	2280 [1076]	1900 [897]	1520 [717]	
DR ①		0	.04	.08	0	.04	.08	0	.04	.08	
OUTDOOR DRY BULB TEMPERATURE °F [°C]	75 [23.9]	Total BTUH [kW] Sens BTUH [kW] Power	78.4 [23.0] 49.9 [14.6] 3.7	75.7 [22.2] 42.9 [12.6] 3.6	72.9 [21.4] 36.4 [10.7] 3.6	72.6 [21.3] 58.6 [17.2] 3.7	70.1 [20.5] 51.1 [15.0] 3.6	67.5 [19.8] 44.0 [12.9] 3.5	69.8 [20.5] 66.5 [19.5] 3.6	67.4 [19.8] 58.4 [17.1] 3.6	64.9 [19.0] 50.7 [14.9] 3.5
	80 [26.7]	Total BTUH [kW] Sens BTUH [kW] Power	76.0 [22.3] 48.5 [14.2] 3.9	73.3 [21.5] 41.7 [12.2] 3.8	70.7 [20.7] 35.5 [10.4] 3.8	70.2 [20.6] 57.4 [16.8] 3.9	67.8 [19.9] 50.1 [14.7] 3.8	65.3 [19.1] 43.2 [12.7] 3.7	67.4 [19.8] 65.2 [19.1] 3.8	65.1 [19.1] 57.3 [16.8] 3.8	62.7 [18.4] 49.8 [14.6] 3.7
	85 [29.4]	Total BTUH [kW] Sens BTUH [kW] Power	73.7 [21.6] 47.5 [13.9] 4.1	71.1 [20.8] 40.8 [12.0] 4.1	68.5 [20.1] 34.6 [10.2] 4.0	67.9 [19.9] 56.2 [16.5] 4.1	65.5 [19.2] 49.0 [14.4] 4.0	63.1 [18.5] 42.3 [12.4] 4.0	65.1 [19.1] 64.0 [18.8] 4.1	62.8 [18.4] 56.2 [16.5] 4.0	60.5 [17.7] 48.9 [14.3] 3.9
	90 [32.2]	Total BTUH [kW] Sens BTUH [kW] Power	71.4 [20.9] 46.1 [13.5] 4.4	68.9 [20.2] 39.7 [11.6] 4.3	66.4 [19.5] 33.7 [9.9] 4.2	65.6 [19.2] 55.0 [16.1] 4.3	63.3 [18.6] 48.0 [14.1] 4.3	61.0 [17.9] 41.4 [12.1] 4.2	62.8 [18.4] 62.8 [18.4] 4.3	60.6 [17.8] 55.2 [16.2] 4.2	58.4 [17.1] 48.1 [14.1] 4.1
	95 [35]	Total BTUH [kW] Sens BTUH [kW] Power	69.2 [20.3] 45.0 [13.2] 4.6	66.8 [19.6] 38.8 [11.4] 4.5	64.4 [18.9] 33.0 [9.7] 4.5	63.4 [18.6] 53.8 [15.8] 4.6	61.2 [17.9] 47.0 [13.8] 4.5	59.0 [17.3] 40.6 [11.9] 4.4	60.6 [17.8] 60.6 [17.8] 4.5	58.5 [17.1] 54.2 [15.9] 4.5	56.4 [16.5] 47.2 [13.8] 4.4
	100 [37.8]	Total BTUH [kW] Sens BTUH [kW] Power	67.1 [19.7] 43.8 [12.8] 4.9	64.7 [19.0] 37.7 [11.1] 4.8	62.4 [18.3] 32.1 [9.4] 4.7	61.3 [18.0] 52.7 [15.5] 4.8	59.2 [17.3] 46.1 [13.5] 4.8	57.0 [16.7] 39.8 [11.7] 4.7	58.5 [17.1] 58.5 [17.2] 4.8	56.5 [16.6] 53.3 [15.6] 4.7	54.4 [15.9] 46.4 [13.6] 4.6
	105 [40.6]	Total BTUH [kW] Sens BTUH [kW] Power	65.1 [19.1] 42.7 [12.5] 5.1	62.8 [18.4] 36.8 [10.8] 5.1	60.5 [17.7] 31.3 [9.2] 5.0	59.3 [17.4] 51.6 [15.1] 5.1	57.2 [16.8] 45.1 [13.2] 5.0	55.1 [16.1] 39.0 [11.4] 4.9	56.5 [16.6] 56.5 [16.6] 5.1	54.5 [16.0] 52.3 [15.3] 5.0	52.5 [15.4] 45.6 [13.4] 4.9
	110 [43.3]	Total BTUH [kW] Sens BTUH [kW] Power	63.1 [18.5] 41.7 [12.2] 5.4	60.9 [17.8] 35.9 [10.5] 5.3	58.7 [17.2] 30.6 [9.0] 5.2	57.3 [16.8] 50.5 [14.8] 5.4	55.3 [16.2] 44.2 [13.0] 5.3	53.3 [15.6] 38.3 [11.2] 5.2	54.5 [16.0] 54.5 [16.0] 5.4	52.6 [15.4] 51.4 [15.1] 5.3	50.7 [14.9] 44.9 [13.2] 5.2
	115 [46.1]	Total BTUH [kW] Sens BTUH [kW] Power	61.2 [17.9] 40.6 [11.9] 5.7	59.1 [17.3] 35.0 [10.3] 5.6	56.9 [16.7] 29.7 [8.7] 5.5	55.4 [16.2] 49.4 [14.5] 5.7	53.5 [15.7] 43.3 [12.7] 5.6	51.5 [15.1] 37.4 [11.0] 5.5	52.6 [15.4] 52.6 [15.4] 5.7	50.8 [14.9] 50.5 [14.8] 5.6	48.9 [14.3] 44.1 [12.9] 5.5

DR —Depression ratio  
dbE —Entering air dry bulb  
wbE—Entering air wet bulb

Total —Total capacity x 1000 BTUH  
Sens —Sensible capacity x 1000 BTUH  
Power —KW input

NOTES: ① When the entering air dry bulb is other than 80°F [27°C], adjust the sensible capacity from the table by adding [1.10 x CFM x (1 – DR) x (dbE – 80)].

[ ] Designates Metric Conversions

## GROSS SYSTEMS COOLING PERFORMANCE DATA—TZHH6-A024

ENTERING INDOOR AIR @ 80°F [26.7°C] dbE ①											
wbE		71°F [21.7°C]			67°F [19.4°C]			63°F [17.2°C]			
CFM [L/s]		1200 [566]	900 [425]	800 [378]	1200 [566]	900 [425]	800 [378]	1200 [566]	900 [425]	800 [378]	
DR ①		.03	.06	.06	.03	.06	.06	.03	.06	.06	
OUTDOOR DRY BULB TEMPERATURE °F [°C]	75 [23.9]	Total BTUH [kW] Sens BTUH [kW] Power	36.9 [10.8] 29.4 [8.6] 1.5	34.8 [10.2] 23.3 [6.8] 1.4	34.1 [10.0] 21.4 [6.3] 1.4	29.9 [8.8] 27.4 [8.0] 1.5	28.2 [8.3] 22.0 [6.5] 1.4	27.6 [8.1] 20.3 [6.0] 1.4	16.5 [4.8] 15.8 [4.6] 1.4	15.5 [4.5] 12.7 [3.7] 1.4	15.2 [4.5] 11.8 [3.5] 1.4
	80 [26.7]	Total BTUH [kW] Sens BTUH [kW] Power	35.8 [10.5] 28.7 [8.4] 1.5	33.7 [9.9] 22.7 [6.7] 1.5	33.0 [9.7] 20.9 [6.1] 1.5	28.8 [8.4] 26.7 [7.8] 1.5	27.1 [7.9] 21.4 [6.3] 1.5	26.6 [7.8] 19.8 [5.8] 1.5	15.3 [4.5] 15.1 [4.4] 1.5	14.4 [4.2] 12.2 [3.6] 1.5	14.2 [4.2] 11.4 [3.4] 1.5
	85 [29.4]	Total BTUH [kW] Sens BTUH [kW] Power	34.7 [10.2] 28.0 [8.2] 1.6	32.7 [9.6] 22.2 [6.5] 1.6	32.0 [9.4] 20.4 [6.0] 1.6	27.7 [8.1] 26.0 [7.6] 1.6	26.1 [7.6] 20.9 [6.1] 1.6	25.6 [7.5] 19.3 [5.7] 1.6	14.3 [4.2] 14.3 [4.2] 1.6	13.4 [3.9] 11.7 [3.4] 1.6	13.2 [3.9] 10.9 [3.2] 1.5
	90 [32.2]	Total BTUH [kW] Sens BTUH [kW] Power	33.7 [9.9] 27.5 [8.1] 1.7	31.8 [9.3] 21.9 [6.4] 1.7	31.1 [9.1] 20.1 [5.9] 1.7	26.7 [7.8] 25.5 [7.5] 1.7	25.2 [7.4] 20.6 [6.0] 1.7	24.7 [7.2] 19.1 [5.6] 1.6	13.3 [3.9] 13.3 [3.9] 1.7	12.5 [3.7] 11.4 [3.4] 1.7	12.3 [3.6] 10.6 [3.1] 1.6
	95 [35]	Total BTUH [kW] Sens BTUH [kW] Power	32.8 [9.6] 27.2 [8.0] 1.8	30.9 [9.1] 21.6 [6.3] 1.8	30.3 [8.9] 19.9 [5.8] 1.8	25.8 [7.6] 25.2 [7.4] 1.8	24.3 [7.1] 20.3 [6.0] 1.8	23.8 [7.0] 18.8 [5.5] 1.7	12.3 [3.6] 12.3 [3.6] 1.8	11.6 [3.4] 11.1 [3.3] 1.7	11.4 [3.3] 10.3 [3.0] 1.7
	100 [37.8]	Total BTUH [kW] Sens BTUH [kW] Power	31.9 [9.3] 26.8 [7.9] 1.9	30.1 [8.8] 21.4 [6.3] 1.9	29.5 [8.6] 19.7 [5.8] 1.9	24.9 [7.3] 24.8 [7.3] 1.9	23.5 [6.9] 20.1 [5.9] 1.9	23.0 [6.7] 18.6 [5.5] 1.8	11.5 [3.4] 11.5 [3.4] 1.9	10.8 [3.2] 10.8 [3.2] 1.9	10.6 [3.1] 10.1 [3.0] 1.8
	105 [40.6]	Total BTUH [kW] Sens BTUH [kW] Power	31.2 [9.1] 26.7 [7.8] 2.0	29.4 [8.6] 21.3 [6.3] 2.0	28.8 [8.4] 19.6 [5.8] 2.0	24.2 [7.1] 24.2 [7.1] 2.0	22.8 [6.7] 20.0 [5.9] 2.0	22.3 [6.5] 18.5 [5.4] 2.0	10.7 [3.1] 10.7 [3.1] 2.0	10.1 [3.0] 10.1 [3.0] 2.0	9.9 [2.9] 9.9 [2.9] 1.9
	110 [43.3]	Total BTUH [kW] Sens BTUH [kW] Power	30.5 [8.9] 26.7 [7.8] 2.2	28.7 [8.4] 21.3 [6.3] 2.1	28.2 [8.3] 19.7 [5.8] 2.1	23.5 [6.9] 23.5 [6.9] 2.1	22.1 [6.5] 20.0 [5.9] 2.1	21.7 [6.4] 18.6 [5.5] 2.1	10.0 [2.9] 10.0 [2.9] 2.1	9.5 [2.8] 9.5 [2.8] 2.1	9.3 [2.7] 9.3 [2.7] 2.1
	115 [46.1]	Total BTUH [kW] Sens BTUH [kW] Power	29.9 [8.8] 26.8 [7.9] 2.3	28.2 [8.3] 21.5 [6.3] 2.2	27.6 [8.1] 19.8 [5.8] 2.2	22.9 [6.7] 22.9 [6.7] 2.3	21.6 [6.3] 20.2 [5.9] 2.2	21.1 [6.2] 18.7 [5.5] 2.2	9.4 [2.8] 9.4 [2.8] 2.3	8.9 [2.6] 8.9 [2.6] 2.2	8.7 [2.5] 8.7 [2.6] 2.2

## GROSS SYSTEMS COOLING PERFORMANCE DATA—TZHH6-A030

ENTERING INDOOR AIR @ 80°F [26.7°C] dbE ①											
wbE		71°F [21.7°C]			67°F [19.4°C]			63°F [17.2°C]			
CFM [L/s]		1200 [566]	1000 [472]	800 [378]	1200 [566]	1000 [472]	800 [378]	1200 [566]	1000 [472]	800 [378]	
DR ①		.04	.06	.09	.04	.06	.09	.04	.06	.09	
OUTDOOR DRY BULB TEMPERATURE °F [°C]	75 [23.9]	Total BTUH [kW] Sens BTUH [kW] Power	37.9 [11.1] 25.4 [7.5] 1.7	36.6 [10.7] 21.9 [6.4] 1.6	35.2 [10.3] 18.6 [5.5] 1.6	35.9 [10.5] 29.6 [8.7] 1.6	34.6 [10.1] 25.8 [7.6] 1.6	33.3 [9.8] 22.2 [6.5] 1.6	34.2 [10.0] 32.5 [9.5] 1.6	33.0 [9.7] 28.5 [8.4] 1.6	31.8 [9.3] 24.8 [7.3] 1.6
	80 [26.7]	Total BTUH [kW] Sens BTUH [kW] Power	36.7 [10.8] 24.7 [7.2] 1.7	35.4 [10.4] 21.3 [6.3] 1.7	34.2 [10.0] 18.2 [5.3] 1.7	34.7 [10.2] 29.0 [8.5] 1.7	33.5 [9.8] 25.3 [7.4] 1.7	32.3 [9.5] 21.9 [6.4] 1.7	33.1 [9.7] 31.9 [9.4] 1.7	31.9 [9.3] 28.0 [8.2] 1.7	30.7 [9.0] 24.3 [7.1] 1.6
	85 [29.4]	Total BTUH [kW] Sens BTUH [kW] Power	35.5 [10.4] 24.1 [7.1] 1.8	34.2 [10.0] 20.7 [6.1] 1.8	33.0 [9.7] 17.7 [5.2] 1.8	33.5 [9.8] 28.3 [8.3] 1.8	32.3 [9.5] 24.7 [7.2] 1.8	31.1 [9.1] 21.3 [6.3] 1.8	31.8 [9.3] 31.2 [9.2] 1.8	30.7 [9.0] 27.4 [8.0] 1.8	29.6 [8.7] 23.8 [7.0] 1.7
	90 [32.2]	Total BTUH [kW] Sens BTUH [kW] Power	34.2 [10.0] 23.4 [6.9] 1.9	33.0 [9.7] 20.2 [5.9] 1.9	31.8 [9.3] 17.2 [5.1] 1.9	32.1 [9.4] 27.6 [8.1] 1.9	31.0 [9.1] 24.1 [7.1] 1.9	29.9 [8.8] 20.9 [6.1] 1.9	30.5 [8.9] 30.5 [8.9] 1.9	29.4 [8.6] 26.8 [7.9] 1.9	28.3 [8.3] 23.3 [6.8] 1.8
	95 [35]	Total BTUH [kW] Sens BTUH [kW] Power	32.7 [9.6] 22.6 [6.6] 2.1	31.6 [9.3] 19.6 [5.8] 2.0	30.4 [8.9] 16.7 [4.9] 2.0	30.7 [9.0] 26.8 [7.9] 2.0	29.6 [8.7] 23.4 [6.9] 2.0	28.5 [8.4] 20.2 [5.9] 2.0	29.0 [8.5] 29.0 [8.5] 2.0	28.0 [8.2] 26.1 [7.7] 2.0	27.0 [7.9] 22.8 [6.7] 2.0
	100 [37.8]	Total BTUH [kW] Sens BTUH [kW] Power	31.2 [9.1] 21.9 [6.4] 2.2	30.1 [8.8] 18.9 [5.5] 2.1	29.0 [8.5] 16.1 [4.7] 2.1	29.2 [8.6] 26.0 [7.6] 2.2	28.1 [8.2] 22.7 [6.7] 2.1	27.1 [7.9] 19.7 [5.8] 2.1	27.5 [8.1] 27.5 [8.1] 2.2	26.6 [7.8] 25.5 [7.5] 2.1	25.6 [7.5] 22.2 [6.5] 2.1
	105 [40.6]	Total BTUH [kW] Sens BTUH [kW] Power	29.6 [8.7] 21.0 [6.2] 2.3	28.5 [8.4] 18.1 [5.3] 2.3	27.5 [8.1] 15.5 [4.6] 2.2	27.5 [8.1] 25.1 [7.4] 2.3	26.6 [7.8] 22.1 [6.5] 2.3	25.6 [7.5] 19.1 [5.6] 2.2	25.9 [7.6] 25.9 [7.6] 2.3	25.0 [7.3] 24.8 [7.3] 2.2	24.1 [7.1] 21.7 [6.4] 2.2
	110 [43.3]	Total BTUH [kW] Sens BTUH [kW] Power	27.9 [8.2] 20.1 [5.9] 2.5	26.9 [7.9] 17.4 [5.1] 2.4	25.9 [7.6] 14.9 [4.4] 2.4	25.8 [7.6] 24.3 [7.1] 2.4	24.9 [7.3] 21.3 [6.3] 2.4	24.0 [7.0] 18.5 [5.4] 2.4	24.2 [7.1] 24.2 [7.1] 2.4	23.3 [6.8] 23.3 [6.8] 2.4	22.5 [6.6] 20.9 [6.1] 2.3
	115 [46.1]	Total BTUH [kW] Sens BTUH [kW] Power	26.0 [7.6] 19.0 [5.6] 2.6	25.1 [7.4] 16.5 [4.8] 2.6	24.2 [7.1] 14.1 [4.1] 2.5	24.0 [7.0] 23.3 [6.8] 2.6	23.2 [6.8] 20.5 [6.0] 2.6	22.3 [6.5] 17.8 [5.2] 2.5	22.4 [6.6] 22.4 [6.6] 2.6	21.6 [6.3] 21.6 [6.3] 2.5	20.8 [6.1] 20.3 [6.0] 2.5

DR —Depression ratio  
dbE —Entering air dry bulb  
wbE—Entering air wet bulb

Total —Total capacity x 1000 BTUH  
Sens —Sensible capacity x 1000 BTUH  
Power—KW input

NOTES: ① When the entering air dry bulb is other than 80°F [27°C], adjust the sensible capacity from the table by adding  $[1.10 \times \text{CFM} \times (1 - \text{DR}) \times (\text{dbE} - 80)]$ .

[ ] Designates Metric Conversions

## GROSS SYSTEMS COOLING PERFORMANCE DATA—TZHH6-A036

ENTERING INDOOR AIR @ 80°F [26.7°C] dbE ①											
wbE		71°F [21.7°C]			67°F [19.4°C]			63°F [17.2°C]			
CFM [L/s]		1440 [680]	1200 [566]	960 [453]	1440 [680]	1200 [566]	960 [453]	1440 [680]	1200 [566]	960 [453]	
DR ①		.0	.0	.0	.0	.0	.0	.0	.0	.0	
OUTDOOR DRY BULB TEMPERATURE °F [°C]	75 [23.9]	Total BTUH [kW]	44.7 [13.1]	43.1 [12.6]	41.5 [12.2]	41.6 [12.2]	40.2 [11.8]	38.7 [11.3]	39.9 [11.7]	38.5 [11.3]	37.1 [10.9]
		Sens BTUH [kW]	31.6 [9.3]	27.3 [8.0]	23.3 [6.8]	37.0 [10.9]	32.4 [9.5]	28.0 [8.2]	39.9 [11.7]	35.3 [10.4]	30.7 [9.0]
		Power	2.0	2.0	1.9	2.0	1.9	1.9	2.0	1.9	1.9
	80 [26.7]	Total BTUH [kW]	43.3 [12.7]	41.8 [12.3]	40.3 [11.8]	40.3 [11.8]	38.9 [11.4]	37.4 [11.0]	38.6 [11.3]	37.2 [10.9]	35.9 [10.5]
		Sens BTUH [kW]	31.2 [9.2]	27.0 [7.9]	23.1 [6.8]	36.6 [10.7]	32.1 [9.4]	27.7 [8.1]	38.6 [11.3]	35.0 [10.3]	30.6 [9.0]
		Power	2.1	2.1	2.0	2.1	2.0	2.0	2.1	2.0	2.0
	85 [29.4]	Total BTUH [kW]	42.0 [12.3]	40.5 [11.9]	39.0 [11.4]	38.9 [11.4]	37.5 [11.0]	36.2 [10.6]	37.2 [10.9]	35.9 [10.5]	34.6 [10.1]
		Sens BTUH [kW]	30.6 [9.0]	26.5 [7.8]	22.7 [6.7]	36.0 [10.6]	31.5 [9.2]	27.4 [8.0]	37.2 [10.9]	34.5 [10.1]	30.1 [8.8]
Power		2.2	2.2	2.1	2.2	2.2	2.1	2.2	2.1	2.1	
90 [32.2]	Total BTUH [kW]	40.6 [11.9]	39.2 [11.5]	37.8 [11.1]	37.6 [11.0]	36.3 [10.6]	34.9 [10.2]	35.9 [10.5]	34.6 [10.1]	33.4 [9.8]	
	Sens BTUH [kW]	29.7 [8.7]	25.8 [7.6]	22.1 [6.5]	35.2 [10.3]	30.9 [9.1]	26.7 [7.8]	35.9 [10.5]	33.8 [9.9]	29.6 [8.7]	
	Power	2.3	2.3	2.3	2.3	2.3	2.2	2.3	2.3	2.2	
95 [35]	Total BTUH [kW]	39.3 [11.5]	37.9 [11.1]	36.5 [10.7]	36.2 [10.6]	35.0 [10.3]	33.7 [9.9]	34.5 [10.1]	33.3 [9.8]	32.1 [9.4]	
	Sens BTUH [kW]	28.8 [8.5]	24.9 [7.3]	21.3 [6.3]	34.1 [10.0]	30.0 [8.8]	26.0 [7.6]	34.5 [10.1]	32.9 [9.7]	28.7 [8.4]	
	Power	2.5	2.4	2.4	2.5	2.4	2.4	2.4	2.4	2.4	
100 [37.8]	Total BTUH [kW]	38.0 [11.1]	36.6 [10.7]	35.3 [10.3]	34.9 [10.2]	33.7 [9.9]	32.4 [9.5]	33.2 [9.7]	32.0 [9.4]	30.9 [9.1]	
	Sens BTUH [kW]	27.7 [8.1]	23.9 [7.0]	20.5 [6.0]	33.0 [9.7]	29.0 [8.5]	25.1 [7.4]	33.2 [9.7]	31.9 [9.4]	27.9 [8.2]	
	Power	2.6	2.6	2.5	2.6	2.6	2.5	2.6	2.5	2.5	
105 [40.6]	Total BTUH [kW]	36.6 [10.7]	35.3 [10.3]	34.1 [10.0]	33.6 [9.8]	32.4 [9.5]	31.2 [9.1]	31.9 [9.3]	30.8 [9.0]	29.6 [8.7]	
	Sens BTUH [kW]	26.2 [7.7]	22.7 [6.7]	19.5 [5.7]	31.7 [9.3]	27.8 [8.2]	24.1 [7.1]	31.9 [9.4]	30.8 [9.0]	26.8 [7.9]	
	Power	2.8	2.7	2.7	2.8	2.7	2.7	2.7	2.7	2.6	
110 [43.3]	Total BTUH [kW]	35.3 [10.3]	34.1 [10.0]	32.8 [9.6]	32.2 [9.4]	31.1 [9.1]	30.0 [8.8]	30.6 [9.0]	29.5 [8.6]	28.4 [8.3]	
	Sens BTUH [kW]	24.7 [7.2]	21.4 [6.3]	18.2 [5.3]	30.1 [8.8]	26.4 [7.7]	22.9 [6.7]	30.6 [9.0]	29.4 [8.6]	25.7 [7.5]	
	Power	2.9	2.9	2.8	2.9	2.9	2.8	2.9	2.8	2.8	
115 [46.1]	Total BTUH [kW]	34.0 [10.0]	32.8 [9.6]	31.6 [9.3]	30.9 [9.1]	29.8 [8.7]	28.8 [8.4]	29.2 [8.6]	28.2 [8.3]	27.2 [8.0]	
	Sens BTUH [kW]	23.0 [6.8]	19.8 [5.8]	16.9 [5.0]	28.3 [8.3]	24.8 [7.3]	21.6 [6.3]	29.2 [8.6]	27.8 [8.2]	24.3 [7.1]	
	Power	3.1	3.0	3.0	3.1	3.0	3.0	3.1	3.0	3.0	

## GROSS SYSTEMS COOLING PERFORMANCE DATA—TZHH6-A042

ENTERING INDOOR AIR @ 80°F [26.7°C] dbE ①											
wbE		71°F [21.7°C]			67°F [19.4°C]			63°F [17.2°C]			
CFM [L/s]		1860 [878]	1425 [672]	1240 [585]	1860 [878]	1425 [672]	1240 [585]	1860 [878]	1425 [672]	1240 [585]	
DR ①		.05	.09	.11	.05	.09	.11	.05	.09	.11	
OUTDOOR DRY BULB TEMPERATURE °F [°C]	75 [23.9]	Total BTUH [kW]	54.7 [16.0]	51.9 [15.2]	50.6 [14.8]	51.4 [15.1]	48.7 [14.3]	47.5 [13.9]	48.8 [14.3]	46.2 [13.5]	45.1 [13.2]
		Sens BTUH [kW]	37.1 [10.9]	29.7 [8.7]	26.7 [7.8]	43.4 [12.7]	35.3 [10.4]	32.0 [9.4]	48.1 [14.1]	39.5 [11.6]	36.1 [10.6]
		Power	2.4	2.3	2.3	2.4	2.3	2.3	2.4	2.3	2.3
	80 [26.7]	Total BTUH [kW]	53.4 [15.6]	50.6 [14.8]	49.4 [14.5]	50.1 [14.7]	47.4 [13.9]	46.3 [13.6]	47.4 [13.9]	44.9 [13.2]	43.9 [12.9]
		Sens BTUH [kW]	36.6 [10.7]	29.2 [8.6]	26.3 [7.7]	42.8 [12.6]	34.8 [10.2]	31.7 [9.3]	47.4 [13.9]	39.0 [11.4]	35.7 [10.5]
		Power	2.5	2.5	2.4	2.5	2.5	2.4	2.5	2.4	2.4
	85 [29.4]	Total BTUH [kW]	52.0 [15.2]	49.2 [14.4]	48.1 [14.1]	48.6 [14.2]	46.0 [13.5]	45.0 [13.2]	46.0 [13.5]	43.5 [12.7]	42.5 [12.5]
		Sens BTUH [kW]	35.9 [10.5]	28.6 [8.4]	25.8 [7.6]	42.0 [12.3]	34.2 [10.0]	31.2 [9.2]	46.0 [13.5]	38.4 [11.3]	35.1 [10.3]
Power		2.7	2.6	2.6	2.7	2.6	2.6	2.7	2.6	2.6	
90 [32.2]	Total BTUH [kW]	50.3 [14.7]	47.7 [14.0]	46.5 [13.6]	47.0 [13.8]	44.5 [13.0]	43.4 [12.7]	44.3 [13.0]	42.0 [12.3]	41.0 [12.0]	
	Sens BTUH [kW]	35.1 [10.3]	28.1 [8.2]	25.3 [7.4]	41.4 [12.1]	33.7 [9.9]	30.6 [9.0]	44.3 [13.0]	37.9 [11.1]	34.7 [10.2]	
	Power	2.8	2.8	2.7	2.8	2.7	2.7	2.8	2.7	2.7	
95 [35]	Total BTUH [kW]	48.5 [14.2]	46.0 [13.5]	44.9 [13.2]	45.2 [13.2]	42.8 [12.5]	41.8 [12.3]	42.5 [12.5]	40.3 [11.8]	39.3 [11.5]	
	Sens BTUH [kW]	34.2 [10.0]	27.4 [8.0]	24.7 [7.2]	40.4 [11.9]	33.0 [9.7]	30.1 [8.8]	42.5 [12.5]	37.2 [10.9]	34.0 [10.0]	
	Power	3.0	2.9	2.9	3.0	2.9	2.9	3.0	2.9	2.9	
100 [37.8]	Total BTUH [kW]	46.6 [13.7]	44.1 [12.9]	43.1 [12.6]	43.2 [12.7]	40.9 [12.0]	40.0 [11.7]	40.6 [11.9]	38.4 [11.3]	37.5 [11.0]	
	Sens BTUH [kW]	33.2 [9.7]	26.6 [7.8]	24.0 [7.0]	39.4 [11.6]	32.2 [9.4]	29.4 [8.6]	40.6 [11.9]	36.4 [10.7]	33.3 [9.8]	
	Power	3.2	3.1	3.1	3.2	3.1	3.0	3.1	3.1	3.0	
105 [40.6]	Total BTUH [kW]	44.5 [13.0]	42.1 [12.3]	41.1 [12.0]	41.1 [12.0]	38.9 [11.4]	38.0 [11.1]	38.5 [11.3]	36.4 [10.7]	35.6 [10.4]	
	Sens BTUH [kW]	32.2 [9.4]	25.8 [7.6]	23.3 [6.8]	38.4 [11.3]	31.4 [9.2]	28.7 [8.4]	38.5 [11.3]	35.6 [10.4]	32.7 [9.6]	
	Power	3.4	3.3	3.2	3.3	3.3	3.2	3.3	3.2	3.2	
110 [43.3]	Total BTUH [kW]	42.2 [12.4]	40.0 [11.7]	39.0 [11.4]	38.8 [11.4]	36.8 [10.8]	35.9 [10.5]	36.2 [10.6]	34.3 [10.1]	33.5 [9.8]	
	Sens BTUH [kW]	31.1 [9.1]	25.0 [7.3]	22.5 [6.6]	37.2 [10.9]	30.6 [9.0]	27.9 [8.2]	36.2 [10.6]	34.3 [10.1]	31.9 [9.4]	
	Power	3.5	3.5	3.4	3.5	3.4	3.4	3.5	3.4	3.4	
115 [46.1]	Total BTUH [kW]	39.8 [11.7]	37.7 [11.0]	36.8 [10.8]	36.4 [10.7]	34.5 [10.1]	33.7 [9.9]	33.8 [9.9]	32.0 [9.4]	31.2 [9.1]	
	Sens BTUH [kW]	29.9 [8.8]	24.1 [7.1]	21.8 [6.4]	36.1 [10.6]	29.7 [8.7]	27.1 [8.0]	33.8 [9.9]	32.0 [9.4]	31.1 [9.1]	
	Power	3.7	3.6	3.6	3.7	3.6	3.6	3.7	3.6	3.6	

DR —Depression ratio  
dbE —Entering air dry bulb  
wbE—Entering air wet bulb

Total —Total capacity x 1000 BTUH  
Sens —Sensible capacity x 1000 BTUH  
Power—KW input

NOTES: ① When the entering air dry bulb is other than 80°F [27°C], adjust the sensible capacity from the table by adding  $[1.10 \times \text{CFM} \times (1 - \text{DR}) \times (\text{dbE} - 80)]$ .

[ ] Designates Metric Conversions

## GROSS SYSTEMS COOLING PERFORMANCE DATA—TZHH6-A048

ENTERING INDOOR AIR @ 80°F [26.7°C] dbE ①											
wbE			71°F [21.7°C]			67°F [19.4°C]			63°F [17.2°C]		
CFM [L/s]			1860 [878]	1525 [720]	1240 [585]	1860 [878]	1525 [720]	1240 [585]	1860 [878]	1525 [720]	1240 [585]
DR ①			.05	.09	.12	.05	.09	.12	.05	.09	.12
OUTDOOR DRY BULB TEMPERATURE °F [°C]	75 [23.9]	Total BTUH [kW]	56.7 [16.6]	54.6 [16.0]	52.7 [15.4]	53.8 [15.8]	51.7 [15.2]	50.0 [14.7]	50.6 [14.8]	48.7 [14.3]	47.0 [13.8]
		Sens BTUH [kW]	36.8 [10.8]	31.3 [9.2]	26.8 [7.9]	43.8 [12.8]	37.6 [11.0]	32.8 [9.6]	48.3 [14.2]	41.9 [12.3]	36.7 [10.8]
		Power	2.6	2.5	2.5	2.5	2.5	2.4	2.5	2.4	2.4
	80 [26.7]	Total BTUH [kW]	55.8 [16.4]	53.6 [15.7]	51.8 [15.2]	52.8 [15.5]	50.8 [14.9]	49.0 [14.4]	49.6 [14.5]	47.7 [14.0]	46.1 [13.5]
		Sens BTUH [kW]	36.6 [10.7]	31.0 [9.1]	26.7 [7.8]	43.4 [12.7]	37.4 [11.0]	32.5 [9.5]	48.0 [14.1]	41.6 [12.2]	36.5 [10.7]
		Power	2.7	2.7	2.6	2.7	2.6	2.6	2.6	2.6	2.6
	85 [29.4]	Total BTUH [kW]	54.5 [16.0]	52.4 [15.4]	50.6 [14.8]	51.6 [15.1]	49.6 [14.5]	47.9 [14.0]	48.4 [14.2]	46.5 [13.6]	45.0 [13.2]
		Sens BTUH [kW]	36.1 [10.6]	30.6 [9.0]	26.3 [7.7]	43.0 [12.6]	37.0 [10.9]	32.2 [9.4]	47.5 [13.9]	41.2 [12.1]	36.2 [10.6]
		Power	2.9	2.8	2.8	2.8	2.8	2.7	2.8	2.8	2.7
	90 [32.2]	Total BTUH [kW]	53.1 [15.6]	51.0 [14.9]	49.3 [14.4]	50.1 [14.7]	48.2 [14.1]	46.5 [13.6]	46.9 [13.7]	45.1 [13.2]	43.6 [12.8]
Sens BTUH [kW]		35.5 [10.4]	30.1 [8.8]	25.9 [7.6]	42.3 [12.4]	36.5 [10.7]	31.8 [9.3]	46.9 [13.8]	40.7 [11.9]	35.8 [10.5]	
Power		3.1	3.0	2.9	3.0	3.0	2.9	3.0	2.9	2.9	
95 [35]	Total BTUH [kW]	51.3 [15.0]	49.4 [14.5]	47.7 [14.0]	48.4 [14.2]	46.5 [13.6]	45.0 [13.2]	45.2 [13.2]	43.5 [12.7]	42.0 [12.3]	
	Sens BTUH [kW]	34.5 [10.1]	29.4 [8.6]	25.3 [7.4]	41.5 [12.2]	35.7 [10.5]	31.2 [9.2]	45.2 [13.3]	40.0 [11.7]	35.1 [10.3]	
	Power	3.2	3.2	3.1	3.2	3.1	3.1	3.2	3.1	3.1	
100 [37.8]	Total BTUH [kW]	49.4 [14.5]	47.5 [13.9]	45.9 [13.5]	46.4 [13.6]	44.6 [13.1]	43.1 [12.6]	43.3 [12.7]	41.6 [12.2]	40.2 [11.8]	
	Sens BTUH [kW]	33.5 [9.8]	28.5 [8.4]	24.6 [7.2]	40.4 [11.9]	34.8 [10.2]	30.4 [8.9]	43.3 [12.7]	39.1 [11.5]	34.4 [10.1]	
	Power	3.4	3.4	3.3	3.4	3.3	3.3	3.4	3.3	3.3	
105 [40.6]	Total BTUH [kW]	47.2 [13.8]	45.4 [13.3]	43.8 [12.8]	44.2 [13.0]	42.5 [12.5]	41.1 [12.0]	41.1 [12.0]	39.5 [11.6]	38.1 [11.2]	
	Sens BTUH [kW]	32.2 [9.4]	27.4 [8.0]	23.5 [6.9]	39.0 [11.4]	33.7 [9.9]	29.5 [8.7]	41.1 [12.1]	38.0 [11.1]	33.4 [9.8]	
	Power	3.7	3.6	3.5	3.6	3.6	3.5	3.6	3.5	3.5	
110 [43.3]	Total BTUH [kW]	44.7 [13.1]	43.0 [12.6]	41.6 [12.2]	41.8 [12.3]	40.2 [11.8]	38.8 [11.4]	38.6 [11.3]	37.1 [10.9]	35.9 [10.5]	
	Sens BTUH [kW]	30.7 [9.0]	26.1 [7.7]	22.5 [6.6]	37.6 [11.0]	32.5 [9.5]	28.4 [8.3]	38.6 [11.3]	36.7 [10.8]	32.4 [9.5]	
	Power	3.9	3.8	3.8	3.9	3.8	3.7	3.8	3.8	3.7	
115 [46.1]	Total BTUH [kW]	42.1 [12.3]	40.4 [11.8]	39.1 [11.5]	39.1 [11.5]	37.6 [11.0]	36.3 [10.6]	35.9 [10.5]	34.5 [10.1]	33.4 [9.8]	
	Sens BTUH [kW]	29.0 [8.5]	24.6 [7.2]	21.3 [6.3]	35.8 [10.5]	31.0 [9.1]	27.1 [8.0]	35.9 [10.5]	34.5 [10.1]	31.2 [9.2]	
	Power	4.1	4.1	4.0	4.1	4.0	4.0	4.1	4.0	3.9	

## GROSS SYSTEMS COOLING PERFORMANCE DATA—TZHH6-A060

ENTERING INDOOR AIR @ 80°F [26.7°C] dbE ①											
wbE			71°F [21.7°C]			67°F [19.4°C]			63°F [17.2°C]		
CFM [L/s]			1860 [878]	1900 [897]	1240 [585]	1860 [878]	1900 [897]	1240 [585]	1860 [878]	1900 [897]	1240 [585]
DR ①			.15	.14	.23	.15	.14	.23	.15	.14	.23
OUTDOOR DRY BULB TEMPERATURE °F [°C]	75 [23.9]	Total BTUH [kW]	69.0 [20.2]	69.2 [20.3]	64.9 [19.0]	65.3 [19.1]	65.6 [19.2]	61.5 [18.0]	62.0 [18.2]	62.2 [18.2]	58.3 [17.1]
		Sens BTUH [kW]	38.4 [11.3]	39.0 [11.4]	29.1 [8.5]	45.5 [13.3]	46.3 [13.6]	35.4 [10.4]	51.2 [15.0]	51.9 [15.2]	40.2 [11.8]
		Power	3.5	3.5	3.4	3.5	3.5	3.4	3.4	3.4	3.3
	80 [26.7]	Total BTUH [kW]	67.1 [19.7]	67.3 [19.7]	63.1 [18.5]	63.4 [18.6]	63.7 [18.7]	59.7 [17.5]	60.0 [17.6]	60.3 [17.7]	56.5 [16.6]
		Sens BTUH [kW]	37.6 [11.0]	38.2 [11.2]	28.5 [8.4]	44.7 [13.1]	45.4 [13.3]	34.7 [10.2]	50.3 [14.8]	51.1 [15.0]	39.6 [11.6]
		Power	3.7	3.7	3.6	3.6	3.7	3.5	3.6	3.6	3.5
	85 [29.4]	Total BTUH [kW]	65.0 [19.0]	65.3 [19.1]	61.2 [17.9]	61.4 [18.0]	61.6 [18.1]	57.8 [16.9]	58.0 [17.0]	58.2 [17.1]	54.6 [16.0]
		Sens BTUH [kW]	36.6 [10.7]	37.3 [10.9]	27.8 [8.2]	43.9 [12.9]	44.5 [13.1]	34.1 [10.0]	49.5 [14.5]	50.2 [14.7]	39.0 [11.4]
		Power	3.9	3.9	3.8	3.8	3.8	3.7	3.8	3.8	3.7
	90 [32.2]	Total BTUH [kW]	62.9 [18.4]	63.2 [18.5]	59.2 [17.3]	59.3 [17.4]	59.5 [17.4]	55.8 [16.4]	55.9 [16.4]	56.1 [16.4]	52.6 [15.4]
Sens BTUH [kW]		35.8 [10.5]	36.5 [10.7]	27.2 [8.0]	43.0 [12.6]	43.6 [12.8]	33.4 [9.8]	48.6 [14.3]	49.3 [14.5]	38.4 [11.3]	
Power		4.1	4.1	4.0	4.0	4.0	3.9	4.0	4.0	3.9	
95 [35]	Total BTUH [kW]	60.7 [17.8]	60.9 [17.8]	57.1 [16.7]	57.0 [16.7]	57.3 [16.8]	53.6 [15.7]	53.7 [15.7]	53.9 [15.8]	50.5 [14.8]	
	Sens BTUH [kW]	35.0 [10.3]	35.5 [10.4]	26.6 [7.8]	42.0 [12.3]	42.7 [12.5]	32.7 [9.6]	47.7 [14.0]	48.4 [14.2]	37.7 [11.1]	
	Power	4.3	4.3	4.2	4.3	4.3	4.1	4.2	4.2	4.1	
100 [37.8]	Total BTUH [kW]	58.3 [17.1]	58.6 [17.2]	54.9 [16.1]	54.7 [16.0]	54.9 [16.1]	51.4 [15.1]	51.3 [15.0]	51.5 [15.1]	48.3 [14.2]	
	Sens BTUH [kW]	34.0 [10.0]	34.6 [10.2]	25.9 [7.6]	41.2 [12.1]	41.8 [12.3]	32.1 [9.4]	46.7 [13.7]	47.4 [13.9]	37.0 [10.9]	
	Power	4.5	4.5	4.4	4.5	4.5	4.3	4.4	4.4	4.3	
105 [40.6]	Total BTUH [kW]	55.9 [16.4]	56.1 [16.4]	52.6 [15.4]	52.2 [15.3]	52.4 [15.4]	49.1 [14.4]	48.9 [14.3]	49.1 [14.4]	46.0 [13.5]	
	Sens BTUH [kW]	33.1 [9.7]	33.6 [9.9]	25.2 [7.4]	40.1 [11.8]	40.7 [11.9]	31.3 [9.2]	45.8 [13.4]	46.5 [13.6]	36.4 [10.7]	
	Power	4.8	4.8	4.6	4.7	4.7	4.6	4.7	4.7	4.5	
110 [43.3]	Total BTUH [kW]	53.3 [15.6]	53.5 [15.7]	50.1 [14.7]	49.7 [14.6]	49.9 [14.6]	46.7 [13.7]	46.3 [13.6]	46.5 [13.6]	43.5 [12.7]	
	Sens BTUH [kW]	32.0 [9.4]	32.5 [9.5]	24.4 [7.2]	39.2 [11.5]	39.8 [11.7]	30.7 [9.0]	44.9 [13.2]	45.5 [13.3]	35.6 [10.4]	
	Power	5.0	5.0	4.9	5.0	5.0	4.8	4.9	4.9	4.8	
115 [46.1]	Total BTUH [kW]	50.7 [14.9]	50.9 [14.9]	47.6 [14.0]	47.0 [13.8]	47.2 [13.8]	44.2 [13.0]	43.6 [12.8]	43.8 [12.8]	41.0 [12.0]	
	Sens BTUH [kW]	31.1 [9.1]	31.6 [9.3]	23.7 [7.0]	38.1 [11.2]	38.7 [11.4]	29.9 [8.8]	43.6 [12.8]	43.8 [12.8]	34.9 [10.2]	
	Power	5.3	5.3	5.1	5.2	5.2	5.1	5.2	5.2	5.0	

DR —Depression ratio  
dbE —Entering air dry bulb  
wbE—Entering air wet bulb

Total —Total capacity x 1000 BTUH  
Sens —Sensible capacity x 1000 BTUH  
Power —KW input

NOTES: ① When the entering air dry bulb is other than 80°F [27°C], adjust the sensible capacity from the table by adding  $[1.10 \times \text{CFM} \times (1 - \text{DR}) \times (\text{dbE} - 80)]$ .

[ ] Designates Metric Conversions

## HEATING PERFORMANCE DATA – TZHH4-A024

IDB		60°F [15.5°C]			70°F [21.1°C]			80°F [26.7°C]			
		CFM [L/s]	960 [453]	800 [378]	640 [302]	960 [453]	800 [378]	640 [302]	960 [453]	800 [378]	640 [302]
OUTDOOR DRY BULB TEMPERATURE °F [°C]	0 [-17.8]	Total BTUH [kW] Power	8.3 [2.4] 1.4	8.2 [2.4] 1.4	8.1 [2.4] 1.5	7.4 [2.2] 1.5	7.3 [2.1] 1.6	7.2 [2.1] 1.6	6.4 [1.9] 1.8	6.3 [1.8] 1.8	6.2 [1.8] 1.9
	5 [-15]	Total BTUH [kW] Power	10.0 [2.9] 1.4	9.9 [2.9] 1.5	9.7 [2.8] 1.5	9.1 [2.7] 1.5	8.9 [2.6] 1.6	8.8 [2.6] 1.6	8.1 [2.4] 1.8	8.0 [2.3] 1.8	7.9 [2.3] 1.9
	10 [-12.2]	Total BTUH [kW] Power	11.7 [3.4] 1.4	11.5 [3.4] 1.5	11.4 [3.3] 1.5	10.7 [3.1] 1.6	10.6 [3.1] 1.6	10.4 [3.0] 1.7	9.8 [2.9] 1.8	9.6 [2.8] 1.9	9.5 [2.8] 1.9
	15 [-9.4]	Total BTUH [kW] Power	13.4 [3.9] 1.5	13.2 [3.9] 1.5	13.0 [3.8] 1.5	12.4 [3.6] 1.6	12.2 [3.6] 1.6	12.1 [3.5] 1.7	11.4 [3.3] 1.9	11.3 [3.3] 1.9	11.1 [3.3] 1.9
	20 [-6.7]	Total BTUH [kW] Power	15.0 [4.4] 1.5	14.8 [4.3] 1.5	14.6 [4.3] 1.6	14.1 [4.1] 1.6	13.9 [4.1] 1.7	13.7 [4.0] 1.7	13.1 [3.8] 1.9	12.9 [3.8] 1.9	12.7 [3.7] 2.0
	25 [-3.9]	Total BTUH [kW] Power	16.7 [4.9] 1.5	16.5 [4.8] 1.6	16.2 [4.7] 1.6	15.8 [4.6] 1.7	15.5 [4.5] 1.7	15.3 [4.5] 1.7	14.8 [4.3] 1.9	14.6 [4.3] 2.0	14.4 [4.2] 2.0
	30 [-1.1]	Total BTUH [kW] Power	18.4 [5.4] 1.6	18.1 [5.3] 1.6	17.9 [5.2] 1.6	17.4 [5.1] 1.7	17.2 [5.0] 1.7	16.9 [5.0] 1.8	16.5 [4.8] 1.9	16.2 [4.7] 2.0	16.0 [4.7] 2.0
	35 [1.7]	Total BTUH [kW] Power	20.1 [5.9] 1.6	19.8 [5.8] 1.6	19.5 [5.7] 1.7	19.1 [5.6] 1.7	18.8 [5.5] 1.8	18.6 [5.5] 1.8	18.1 [5.3] 2.0	17.9 [5.2] 2.0	17.6 [5.2] 2.1
	40 [4.4]	Total BTUH [kW] Power	21.7 [6.4] 1.6	21.4 [6.3] 1.7	21.1 [6.2] 1.7	20.8 [6.1] 1.7	20.5 [6.0] 1.8	20.2 [5.9] 1.8	19.8 [5.8] 2.0	19.5 [5.7] 2.0	19.3 [5.7] 2.1
	45 [7.2]	Total BTUH [kW] Power	23.4 [6.9] 1.6	23.1 [6.8] 1.7	22.7 [6.7] 1.7	22.4 [6.6] 1.8	22.1 [6.5] 1.8	21.8 [6.4] 1.9	21.5 [6.3] 2.0	21.2 [6.2] 2.1	20.9 [6.1] 2.1
50 [10]	Total BTUH [kW] Power	25.1 [7.4] 1.7	24.7 [7.2] 1.7	24.4 [7.2] 1.8	24.1 [7.1] 1.8	23.8 [7.0] 1.8	23.4 [6.9] 1.9	23.2 [6.8] 2.0	22.8 [6.7] 2.1	22.5 [6.6] 2.2	

IDB —Indoor air dry bulb

## HEATING PERFORMANCE DATA – TZHH4-A030

IDB		60°F [15.5°C]			70°F [21.1°C]			80°F [26.7°C]			
		CFM [L/s]	1200 [566]	1000 [472]	800 [378]	1200 [566]	1000 [472]	800 [378]	1200 [566]	1000 [472]	800 [378]
OUTDOOR DRY BULB TEMPERATURE °F [°C]	0 [-17.8]	Total BTUH [kW] Power	9.0 [2.6] 1.6	8.9 [2.6] 1.6	8.8 [2.6] 1.7	7.6 [2.2] 1.7	7.5 [2.2] 1.8	7.4 [2.2] 1.8	6.3 [1.8] 2.0	6.2 [1.8] 2.0	6.1 [1.8] 2.1
	5 [-15]	Total BTUH [kW] Power	11.2 [3.3] 1.6	11.0 [3.2] 1.6	10.8 [3.2] 1.7	9.8 [2.9] 1.8	9.7 [2.8] 1.8	9.5 [2.8] 1.9	8.4 [2.5] 2.0	8.3 [2.4] 2.1	8.2 [2.4] 2.1
	10 [-12.2]	Total BTUH [kW] Power	13.3 [3.9] 1.6	13.1 [3.8] 1.7	12.9 [3.8] 1.7	11.9 [3.5] 1.8	11.8 [3.5] 1.9	11.6 [3.4] 1.9	10.6 [3.1] 2.1	10.4 [3.0] 2.1	10.3 [3.0] 2.2
	15 [-9.4]	Total BTUH [kW] Power	15.5 [4.5] 1.7	15.3 [4.5] 1.7	15.0 [4.4] 1.8	14.1 [4.1] 1.8	13.9 [4.1] 1.9	13.7 [4.0] 1.9	12.7 [3.7] 2.1	12.6 [3.7] 2.1	12.4 [3.6] 2.2
	20 [-6.7]	Total BTUH [kW] Power	17.6 [5.2] 1.7	17.4 [5.1] 1.8	17.1 [5.0] 1.8	16.3 [4.8] 1.9	16.0 [4.7] 1.9	15.8 [4.6] 2.0	14.9 [4.4] 2.1	14.7 [4.3] 2.2	14.5 [4.2] 2.2
	25 [-3.9]	Total BTUH [kW] Power	19.8 [5.8] 1.7	19.5 [5.7] 1.8	19.2 [5.6] 1.8	18.4 [5.4] 1.9	18.2 [5.3] 2.0	17.9 [5.2] 2.0	17.0 [5.0] 2.2	16.8 [4.9] 2.2	16.6 [4.9] 2.3
	30 [-1.1]	Total BTUH [kW] Power	22.0 [6.4] 1.8	21.6 [6.3] 1.8	21.3 [6.2] 1.9	20.6 [6.0] 2.0	20.3 [5.9] 2.0	20.0 [5.9] 2.1	19.2 [5.6] 2.2	18.9 [5.5] 2.2	18.7 [5.5] 2.3
	35 [1.7]	Total BTUH [kW] Power	24.1 [7.1] 1.8	23.8 [7.0] 1.9	23.4 [6.9] 1.9	22.7 [6.7] 2.0	22.4 [6.6] 2.0	22.1 [6.5] 2.1	21.4 [6.3] 2.2	21.1 [6.2] 2.3	20.8 [6.1] 2.3
	40 [4.4]	Total BTUH [kW] Power	26.3 [7.7] 1.9	25.9 [7.6] 1.9	25.5 [7.5] 1.9	24.9 [7.3] 2.0	24.5 [7.2] 2.1	24.2 [7.1] 2.1	23.5 [6.9] 2.3	23.2 [6.8] 2.3	22.9 [6.7] 2.4
	45 [7.2]	Total BTUH [kW] Power	28.4 [8.3] 1.9	28.0 [8.2] 1.9	27.6 [8.1] 2.0	27.1 [7.9] 2.1	26.7 [7.8] 2.1	26.3 [7.7] 2.2	25.7 [7.5] 2.3	25.3 [7.4] 2.4	25.0 [7.3] 2.4
50 [10]	Total BTUH [kW] Power	30.6 [9.0] 1.9	30.2 [8.9] 2.0	29.7 [8.7] 2.0	29.2 [8.6] 2.1	28.8 [8.4] 2.1	28.4 [8.3] 2.2	27.8 [8.1] 2.3	27.4 [8.0] 2.4	27.1 [7.9] 2.4	

IDB —Indoor air dry bulb

[ ] Designates Metric Conversions



## HEATING PERFORMANCE DATA – TZHH4-A036

		IDB	60°F [15.5°C]			70°F [21.1°C]			80°F [26.7°C]		
		CFM [L/s]	1440 [680]	1200 [566]	960 [453]	1440 [680]	1200 [566]	960 [453]	1440 [680]	1200 [566]	960 [453]
OUTDOOR DRY BULB TEMPERATURE °F [°C]	0 [-17.8]	Total BTUH [kW] Power	11.0 [3.2] 1.7	10.9 [3.2] 1.8	10.7 [3.1] 1.8	9.8 [2.9] 2.0	9.6 [2.8] 2.1	9.5 [2.8] 2.1	8.6 [2.5] 2.3	8.4 [2.5] 2.3	8.3 [2.4] 2.4
	5 [-15]	Total BTUH [kW] Power	13.6 [4.0] 1.8	13.4 [3.9] 1.8	13.2 [3.9] 1.9	12.4 [3.6] 2.1	12.2 [3.6] 2.1	12.0 [3.5] 2.2	11.1 [3.3] 2.3	11.0 [3.2] 2.4	10.8 [3.2] 2.4
	10 [-12.2]	Total BTUH [kW] Power	16.2 [4.7] 1.8	15.9 [4.7] 1.9	15.7 [4.6] 1.9	14.9 [4.4] 2.1	14.7 [4.3] 2.2	14.5 [4.2] 2.2	13.7 [4.0] 2.4	13.5 [4.0] 2.4	13.3 [3.9] 2.5
	15 [-9.4]	Total BTUH [kW] Power	18.8 [5.5] 1.9	18.5 [5.4] 1.9	18.2 [5.3] 2.0	17.5 [5.1] 2.2	17.3 [5.1] 2.2	17.0 [5.0] 2.3	16.3 [4.8] 2.4	16.1 [4.7] 2.5	15.9 [4.7] 2.6
	20 [-6.7]	Total BTUH [kW] Power	21.3 [6.2] 1.9	21.0 [6.2] 2.0	20.7 [6.1] 2.0	20.1 [5.9] 2.2	19.8 [5.8] 2.3	19.5 [5.7] 2.4	18.9 [5.5] 2.5	18.6 [5.5] 2.6	18.4 [5.4] 2.6
	25 [-3.9]	Total BTUH [kW] Power	23.9 [7.0] 2.0	23.6 [6.9] 2.0	23.2 [6.8] 2.1	22.7 [6.7] 2.3	22.4 [6.6] 2.3	22.1 [6.5] 2.4	21.5 [6.3] 2.5	21.2 [6.2] 2.6	20.9 [6.1] 2.7
	30 [-1.1]	Total BTUH [kW] Power	26.5 [7.8] 2.1	26.1 [7.6] 2.1	25.7 [7.5] 2.2	25.3 [7.4] 2.3	24.9 [7.3] 2.4	24.6 [7.2] 2.5	24.1 [7.1] 2.6	23.7 [6.9] 2.7	23.4 [6.9] 2.7
	35 [1.7]	Total BTUH [kW] Power	29.1 [8.5] 2.1	28.7 [8.4] 2.2	28.3 [8.3] 2.2	27.9 [8.2] 2.4	27.5 [8.1] 2.5	27.1 [7.9] 2.5	26.6 [7.8] 2.7	26.3 [7.7] 2.7	25.9 [7.6] 2.8
	40 [4.4]	Total BTUH [kW] Power	31.7 [9.3] 2.2	31.2 [9.1] 2.2	30.8 [9.0] 2.3	30.4 [8.9] 2.5	30.0 [8.8] 2.5	29.6 [8.7] 2.6	29.2 [8.6] 2.7	28.8 [8.4] 2.8	28.4 [8.3] 2.8
	45 [7.2]	Total BTUH [kW] Power	34.2 [10.0] 2.2	33.8 [9.9] 2.3	33.3 [9.8] 2.3	33.0 [9.7] 2.5	32.6 [9.6] 2.6	32.1 [9.4] 2.6	31.8 [9.3] 2.8	31.3 [9.2] 2.8	30.9 [9.1] 2.9
50 [10]	Total BTUH [kW] Power	36.8 [10.8] 2.3	36.3 [10.6] 2.3	35.8 [10.5] 2.4	35.6 [10.4] 2.6	35.1 [10.3] 2.6	34.6 [10.1] 2.7	34.4 [10.1] 2.8	33.9 [9.9] 2.9	33.4 [9.8] 3.0	

IDB —Indoor air dry bulb

## HEATING PERFORMANCE DATA – TZHH4-A037

		IDB	60°F [15.5°C]			70°F [21.1°C]			80°F [26.7°C]		
		CFM [L/s]	1440 [680]	1250 [590]	960 [453]	1440 [680]	1250 [590]	960 [453]	1440 [680]	1250 [590]	960 [453]
OUTDOOR DRY BULB TEMPERATURE °F [°C]	0 [-17.8]	Total BTUH [kW] Power	10.4 [3.0] 1.8	10.3 [3.0] 1.8	10.1 [3.0] 1.9	9.3 [2.7] 2.0	9.2 [2.7] 2.1	9.0 [2.6] 2.1	8.1 [2.4] 2.2	8.1 [2.4] 2.3	7.9 [2.3] 2.4
	5 [-15]	Total BTUH [kW] Power	12.9 [3.8] 1.8	12.8 [3.8] 1.9	12.5 [3.7] 1.9	11.8 [3.5] 2.1	11.6 [3.4] 2.1	11.5 [3.4] 2.2	10.7 [3.1] 2.3	10.5 [3.1] 2.3	10.4 [3.0] 2.4
	10 [-12.2]	Total BTUH [kW] Power	15.4 [4.5] 1.9	15.2 [4.5] 1.9	15.0 [4.4] 2.0	14.3 [4.2] 2.1	14.1 [4.1] 2.2	13.9 [4.1] 2.2	13.2 [3.9] 2.3	13.0 [3.8] 2.4	12.8 [3.8] 2.5
	15 [-9.4]	Total BTUH [kW] Power	17.9 [5.2] 1.9	17.7 [5.2] 2.0	17.4 [5.1] 2.0	16.8 [4.9] 2.2	16.6 [4.9] 2.2	16.3 [4.8] 2.3	15.7 [4.6] 2.4	15.5 [4.5] 2.4	15.3 [4.5] 2.5
	20 [-6.7]	Total BTUH [kW] Power	20.4 [6.0] 2.0	20.2 [5.9] 2.0	19.9 [5.8] 2.1	19.3 [5.7] 2.2	19.1 [5.6] 2.3	18.8 [5.5] 2.3	18.2 [5.3] 2.4	18.0 [5.3] 2.5	17.7 [5.2] 2.5
	25 [-3.9]	Total BTUH [kW] Power	22.9 [6.7] 2.0	22.7 [6.7] 2.0	22.3 [6.5] 2.1	21.8 [6.4] 2.3	21.6 [6.3] 2.3	21.2 [6.2] 2.4	20.7 [6.1] 2.5	20.5 [6.0] 2.5	20.1 [5.9] 2.6
	30 [-1.1]	Total BTUH [kW] Power	25.5 [7.5] 2.1	25.2 [7.4] 2.1	24.8 [7.3] 2.2	24.3 [7.1] 2.3	24.1 [7.1] 2.3	23.7 [6.9] 2.4	23.2 [6.8] 2.5	23.0 [6.7] 2.6	22.6 [6.6] 2.6
	35 [1.7]	Total BTUH [kW] Power	28.0 [8.2] 2.1	27.7 [8.1] 2.1	27.2 [8.0] 2.2	26.8 [7.9] 2.3	26.6 [7.8] 2.4	26.1 [7.6] 2.5	25.7 [7.5] 2.6	25.4 [7.4] 2.6	25.0 [7.3] 2.7
	40 [4.4]	Total BTUH [kW] Power	30.5 [8.9] 2.1	30.1 [8.8] 2.2	29.6 [8.7] 2.3	29.4 [8.6] 2.4	29.0 [8.5] 2.4	28.6 [8.4] 2.5	28.2 [8.3] 2.6	27.9 [8.2] 2.7	27.5 [8.1] 2.7
	45 [7.2]	Total BTUH [kW] Power	33.0 [9.7] 2.2	32.6 [9.6] 2.2	32.1 [9.4] 2.3	31.9 [9.3] 2.4	31.5 [9.2] 2.5	31.0 [9.1] 2.6	30.7 [9.0] 2.7	30.4 [8.9] 2.7	29.9 [8.8] 2.8
50 [10]	Total BTUH [kW] Power	35.5 [10.4] 2.2	35.1 [10.3] 2.3	34.5 [10.1] 2.3	34.4 [10.1] 2.5	34.0 [10.0] 2.5	33.4 [9.8] 2.6	33.3 [9.8] 2.7	32.9 [9.6] 2.8	32.4 [9.5] 2.8	

IDB —Indoor air dry bulb

[ ] Designates Metric Conversions

## HEATING PERFORMANCE DATA—TZHH4-A042

IDB		60°F [15.5°C]			70°F [21.1°C]			80°F [26.7°C]			
		CFM [L/s]	1740 [821]	1450 [684]	1160 [547]	1740 [821]	1450 [684]	1160 [547]	1740 [821]	1450 [684]	1160 [547]
OUTDOOR DRY BULB TEMPERATURE °F [°C]	0 [-17.8]	Total BTUH [kW] Power	13.3 [3.9] 2.2	13.1 [3.8] 2.2	12.9 [3.8] 2.3	12.0 [3.5] 2.5	11.9 [3.5] 2.5	11.7 [3.4] 2.6	10.8 [3.2] 2.8	10.6 [3.1] 2.9	10.5 [3.1] 3.0
	5 [-15]	Total BTUH [kW] Power	16.1 [4.7] 2.2	15.8 [4.6] 2.3	15.6 [4.6] 2.4	14.8 [4.3] 2.5	14.6 [4.3] 2.6	14.4 [4.2] 2.7	13.5 [4.0] 2.9	13.4 [3.9] 2.9	13.2 [3.9] 3.0
	10 [-12.2]	Total BTUH [kW] Power	18.9 [5.5] 2.3	18.6 [5.5] 2.4	18.3 [5.4] 2.4	17.6 [5.2] 2.6	17.3 [5.1] 2.7	17.1 [5.0] 2.7	16.3 [4.8] 2.9	16.1 [4.7] 3.0	15.9 [4.7] 3.1
	15 [-9.4]	Total BTUH [kW] Power	21.6 [6.3] 2.4	21.3 [6.2] 2.4	21.0 [6.2] 2.5	20.4 [6.0] 2.6	20.1 [5.9] 2.7	19.8 [5.8] 2.8	19.1 [5.6] 3.0	18.8 [5.5] 3.1	18.6 [5.5] 3.1
	20 [-6.7]	Total BTUH [kW] Power	24.4 [7.2] 2.4	24.1 [7.1] 2.5	23.7 [6.9] 2.5	23.2 [6.8] 2.7	22.8 [6.7] 2.8	22.5 [6.6] 2.8	21.9 [6.4] 3.0	21.6 [6.3] 3.1	21.3 [6.2] 3.2
	25 [-3.9]	Total BTUH [kW] Power	27.2 [8.0] 2.5	26.8 [7.9] 2.5	26.5 [7.8] 2.6	26.0 [7.6] 2.8	25.6 [7.5] 2.8	25.2 [7.4] 2.9	24.7 [7.2] 3.1	24.3 [7.1] 3.2	24.0 [7.0] 3.2
	30 [-1.1]	Total BTUH [kW] Power	30.0 [8.8] 2.5	29.6 [8.7] 2.6	29.2 [8.6] 2.6	28.7 [8.4] 2.8	28.3 [8.3] 2.9	27.9 [8.2] 3.0	27.5 [8.1] 3.1	27.1 [7.9] 3.2	26.7 [7.8] 3.3
	35 [1.7]	Total BTUH [kW] Power	32.8 [9.6] 2.6	32.3 [9.5] 2.6	31.9 [9.3] 2.7	31.5 [9.2] 2.9	31.1 [9.1] 2.9	30.6 [9.0] 3.0	30.3 [8.9] 3.2	29.8 [8.7] 3.3	29.4 [8.6] 3.4
	40 [4.4]	Total BTUH [kW] Power	35.6 [10.4] 2.6	35.1 [10.3] 2.7	34.6 [10.1] 2.8	34.3 [10.1] 2.9	33.8 [9.9] 3.0	33.4 [9.8] 3.1	33.1 [9.7] 3.3	32.6 [9.6] 3.3	32.1 [9.4] 3.4
	45 [7.2]	Total BTUH [kW] Power	38.4 [11.3] 2.7	37.8 [11.1] 2.8	37.3 [10.9] 2.8	37.1 [10.9] 3.0	36.6 [10.7] 3.1	36.1 [10.6] 3.1	35.8 [10.5] 3.3	35.3 [10.3] 3.4	34.8 [10.2] 3.5
50 [10]	Total BTUH [kW] Power	41.2 [12.1] 2.7	40.6 [11.9] 2.8	40.0 [11.7] 2.9	39.9 [11.7] 3.0	39.3 [11.5] 3.1	38.8 [11.4] 3.2	38.6 [11.3] 3.4	38.1 [11.2] 3.4	37.5 [11.0] 3.5	

IDB —Indoor air dry bulb

## HEATING PERFORMANCE DATA—TZHH4-A043

IDB		60°F [15.5°C]			70°F [21.1°C]			80°F [26.7°C]			
		CFM [L/s]	1740 [821]	1425 [673]	1160 [547]	1740 [821]	1425 [673]	1160 [547]	1740 [821]	1425 [673]	1160 [547]
OUTDOOR DRY BULB TEMPERATURE °F [°C]	0 [-17.8]	Total BTUH [kW] Power	12.4 [3.6] 2.3	12.2 [3.6] 2.3	12.1 [3.5] 2.4	11.3 [3.3] 2.5	11.1 [3.3] 2.6	11.0 [3.2] 2.7	10.2 [3.0] 2.9	10.0 [2.9] 3.0	9.9 [2.9] 3.0
	5 [-15]	Total BTUH [kW] Power	15.5 [4.5] 2.3	15.2 [4.5] 2.4	15.0 [4.4] 2.4	14.3 [4.2] 2.6	14.1 [4.1] 2.7	13.9 [4.1] 2.7	13.2 [3.9] 2.9	13.0 [3.8] 3.0	12.8 [3.8] 3.1
	10 [-12.2]	Total BTUH [kW] Power	18.5 [5.4] 2.4	18.2 [5.3] 2.4	18.0 [5.3] 2.5	17.4 [5.1] 2.6	17.1 [5.0] 2.7	16.9 [5.0] 2.8	16.2 [4.7] 3.0	16.0 [4.7] 3.1	15.8 [4.6] 3.1
	15 [-9.4]	Total BTUH [kW] Power	21.5 [6.3] 2.4	21.2 [6.2] 2.5	20.9 [6.1] 2.5	20.4 [6.0] 2.7	20.1 [5.9] 2.8	19.8 [5.8] 2.8	19.3 [5.7] 3.0	19.0 [5.6] 3.1	18.7 [5.5] 3.2
	20 [-6.7]	Total BTUH [kW] Power	24.6 [7.2] 2.5	24.2 [7.1] 2.5	23.9 [7.0] 2.6	23.4 [6.9] 2.7	23.1 [6.8] 2.8	22.8 [6.7] 2.9	22.3 [6.5] 3.1	22.0 [6.4] 3.2	21.7 [6.4] 3.3
	25 [-3.9]	Total BTUH [kW] Power	27.6 [8.1] 2.5	27.2 [8.0] 2.6	26.8 [7.9] 2.6	26.5 [7.8] 2.8	26.1 [7.6] 2.9	25.7 [7.5] 2.9	25.3 [7.4] 3.1	24.9 [7.3] 3.2	24.6 [7.2] 3.3
	30 [-1.1]	Total BTUH [kW] Power	30.6 [9.0] 2.6	30.2 [8.9] 2.6	29.8 [8.7] 2.7	29.5 [8.6] 2.9	29.0 [8.5] 2.9	28.7 [8.4] 3.0	28.4 [8.3] 3.2	27.9 [8.2] 3.3	27.6 [8.1] 3.4
	35 [1.7]	Total BTUH [kW] Power	33.7 [9.9] 2.6	33.1 [9.7] 2.7	32.7 [9.6] 2.8	32.5 [9.5] 2.9	32.0 [9.4] 3.0	31.6 [9.3] 3.1	31.4 [9.2] 3.2	30.9 [9.1] 3.3	30.5 [8.9] 3.4
	40 [4.4]	Total BTUH [kW] Power	36.7 [10.8] 2.7	36.1 [10.6] 2.7	35.6 [10.4] 2.8	35.6 [10.4] 3.0	35.0 [10.3] 3.0	34.5 [10.1] 3.1	34.4 [10.1] 3.3	33.9 [9.9] 3.4	33.4 [9.8] 3.5
	45 [7.2]	Total BTUH [kW] Power	39.7 [11.6] 2.7	39.1 [11.5] 2.8	38.6 [11.3] 2.9	38.6 [11.3] 3.0	38.0 [11.1] 3.1	37.5 [11.0] 3.2	37.5 [11.0] 3.4	36.9 [10.8] 3.4	36.4 [10.7] 3.5
50 [10]	Total BTUH [kW] Power	42.8 [12.5] 2.8	42.1 [12.3] 2.9	41.5 [12.2] 2.9	41.6 [12.2] 3.1	41.0 [12.0] 3.1	40.4 [11.8] 3.2	40.5 [11.9] 3.4	39.9 [11.7] 3.5	39.3 [11.5] 3.6	

IDB —Indoor air dry bulb

[ ] Designates Metric Conversions

## HEATING PERFORMANCE DATA—TZHH4-A048

		IDB	60°F [15.5°C]			70°F [21.1°C]			80°F [26.7°C]		
			CFM [L/s]	1860 [878]	1550 [732]	1240 [585]	1860 [878]	1550 [732]	1240 [585]	1860 [878]	1550 [732]
OUTDOOR DRY BULB TEMPERATURE °F [°C]	0 [-17.8]	Total BTUH [kW]	11.9 [3.5]	11.7 [3.4]	11.5 [3.4]	10.5 [3.1]	10.4 [3.0]	10.2 [3.0]	9.1 [2.7]	9.0 [2.6]	8.9 [2.6]
		Power	2.1	2.2	2.2	2.4	2.5	2.6	2.8	2.9	2.9
	5 [-15]	Total BTUH [kW]	15.2 [4.5]	15.0 [4.4]	14.7 [4.3]	13.8 [4.0]	13.6 [4.0]	13.4 [3.9]	12.5 [3.7]	12.3 [3.6]	12.1 [3.5]
		Power	2.2	2.2	2.3	2.5	2.6	2.6	2.9	2.9	3.0
	10 [-12.2]	Total BTUH [kW]	18.5 [5.4]	18.2 [5.3]	18.0 [5.3]	17.1 [5.0]	16.9 [5.0]	16.6 [4.9]	15.8 [4.6]	15.5 [4.5]	15.3 [4.5]
		Power	2.2	2.3	2.3	2.6	2.6	2.7	2.9	3.0	3.1
	15 [-9.4]	Total BTUH [kW]	21.8 [6.4]	21.5 [6.3]	21.2 [6.2]	20.4 [6.0]	20.1 [5.9]	19.9 [5.8]	19.1 [5.6]	18.8 [5.5]	18.5 [5.4]
		Power	2.3	2.3	2.4	2.6	2.7	2.7	3.0	3.1	3.1
	20 [-6.7]	Total BTUH [kW]	25.1 [7.4]	24.7 [7.2]	24.4 [7.2]	23.7 [6.9]	23.4 [6.9]	23.1 [6.8]	22.4 [6.6]	22.1 [6.5]	21.8 [6.4]
		Power	2.3	2.4	2.5	2.7	2.7	2.8	3.0	3.1	3.2
25 [-3.9]	Total BTUH [kW]	28.4 [8.3]	28.0 [8.2]	27.6 [8.1]	27.1 [7.9]	26.7 [7.8]	26.3 [7.7]	25.7 [7.5]	25.3 [7.4]	25.0 [7.3]	
	Power	2.4	2.5	2.5	2.7	2.8	2.9	3.1	3.2	3.3	
30 [-1.1]	Total BTUH [kW]	31.7 [9.3]	31.3 [9.2]	30.8 [9.0]	30.4 [8.9]	29.9 [8.8]	29.5 [8.6]	29.0 [8.5]	28.6 [8.4]	28.2 [8.3]	
	Power	2.5	2.5	2.6	2.8	2.9	2.9	3.2	3.2	3.3	
35 [1.7]	Total BTUH [kW]	35.0 [10.3]	34.5 [10.1]	34.0 [10.0]	33.7 [9.9]	33.2 [9.7]	32.7 [9.6]	32.3 [9.5]	31.9 [9.3]	31.4 [9.2]	
	Power	2.5	2.6	2.7	2.9	2.9	3.0	3.2	3.3	3.4	
40 [4.4]	Total BTUH [kW]	38.3 [11.2]	37.8 [11.1]	37.3 [10.9]	37.0 [10.8]	36.5 [10.7]	36.0 [10.6]	35.6 [10.4]	35.1 [10.3]	34.6 [10.1]	
	Power	2.6	2.7	2.7	2.9	3.0	3.1	3.3	3.4	3.5	
45 [7.2]	Total BTUH [kW]	41.7 [12.2]	41.1 [12.0]	40.5 [11.9]	40.3 [11.8]	39.7 [11.6]	39.2 [11.5]	39.0 [11.4]	38.4 [11.3]	37.9 [11.1]	
	Power	2.6	2.7	2.8	3.0	3.1	3.1	3.3	3.4	3.5	
50 [10]	Total BTUH [kW]	45.0 [13.2]	44.3 [13.0]	43.7 [12.8]	43.6 [12.8]	43.0 [12.6]	42.4 [12.4]	42.3 [12.4]	41.7 [12.2]	41.1 [12.0]	
	Power	2.7	2.8	2.8	3.0	3.1	3.2	3.4	3.5	3.6	

IDB —Indoor air dry bulb

## HEATING PERFORMANCE DATA—TZHH4-A049

		IDB	60°F [15.5°C]			70°F [21.1°C]			80°F [26.7°C]		
			CFM [L/s]	1860 [878]	1525 [720]	1240 [585]	1860 [878]	1525 [720]	1240 [585]	1860 [878]	1525 [720]
OUTDOOR DRY BULB TEMPERATURE °F [°C]	0 [-17.8]	Total BTUH [kW]	10.4 [3.0]	10.2 [3.0]	10.1 [3.0]	9.4 [2.8]	9.3 [2.7]	9.2 [2.7]	8.5 [2.5]	8.4 [2.5]	8.3 [2.4]
		Power	2.1	2.2	2.2	2.5	2.5	2.6	2.8	2.8	2.9
	5 [-15]	Total BTUH [kW]	13.8 [4.0]	13.6 [4.0]	13.4 [3.9]	12.9 [3.8]	12.7 [3.7]	12.5 [3.7]	11.9 [3.5]	11.8 [3.5]	11.6 [3.4]
		Power	2.2	2.3	2.3	2.5	2.6	2.7	2.8	2.9	3.0
	10 [-12.2]	Total BTUH [kW]	17.2 [5.0]	17.0 [5.0]	16.7 [4.9]	16.3 [4.8]	16.0 [4.7]	15.8 [4.6]	15.4 [4.5]	15.1 [4.4]	14.9 [4.4]
		Power	2.3	2.3	2.4	2.6	2.7	2.7	2.9	3.0	3.0
	15 [-9.4]	Total BTUH [kW]	20.6 [6.0]	20.3 [5.9]	20.1 [5.9]	19.7 [5.8]	19.4 [5.7]	19.2 [5.6]	18.8 [5.5]	18.5 [5.4]	18.3 [5.4]
		Power	2.3	2.4	2.4	2.7	2.7	2.8	3.0	3.0	3.1
	20 [-6.7]	Total BTUH [kW]	24.1 [7.1]	23.7 [6.9]	23.4 [6.9]	23.2 [6.8]	22.8 [6.7]	22.5 [6.6]	22.2 [6.5]	21.9 [6.4]	21.6 [6.3]
		Power	2.4	2.5	2.5	2.7	2.8	2.9	3.0	3.1	3.2
25 [-3.9]	Total BTUH [kW]	27.5 [8.1]	27.1 [7.9]	26.7 [7.8]	26.6 [7.8]	26.2 [7.7]	25.8 [7.6]	25.7 [7.5]	25.3 [7.4]	24.9 [7.3]	
	Power	2.5	2.5	2.6	2.8	2.9	2.9	3.1	3.2	3.2	
30 [-1.1]	Total BTUH [kW]	30.9 [9.1]	30.5 [8.9]	30.1 [8.8]	30.0 [8.8]	29.6 [8.7]	29.2 [8.6]	29.1 [8.5]	28.6 [8.4]	28.3 [8.3]	
	Power	2.5	2.6	2.7	2.9	2.9	3.0	3.2	3.2	3.3	
35 [1.7]	Total BTUH [kW]	34.4 [10.1]	33.8 [9.9]	33.4 [9.8]	33.4 [9.8]	32.9 [9.6]	32.5 [9.5]	32.5 [9.5]	32.0 [9.4]	31.6 [9.3]	
	Power	2.6	2.7	2.7	2.9	3.0	3.1	3.2	3.3	3.4	
40 [4.4]	Total BTUH [kW]	37.8 [11.1]	37.2 [10.9]	36.7 [10.8]	36.9 [10.8]	36.3 [10.6]	35.8 [10.5]	36.0 [10.6]	35.4 [10.4]	34.9 [10.2]	
	Power	2.6	2.7	2.8	3.0	3.1	3.2	3.3	3.4	3.5	
45 [7.2]	Total BTUH [kW]	41.2 [12.1]	40.6 [11.9]	40.0 [11.7]	40.3 [11.8]	39.7 [11.6]	39.2 [11.5]	39.4 [11.5]	38.8 [11.4]	38.3 [11.2]	
	Power	2.7	2.8	2.9	3.1	3.1	3.2	3.3	3.4	3.5	
50 [10]	Total BTUH [kW]	44.7 [13.1]	44.0 [12.9]	43.4 [12.7]	43.7 [12.8]	43.1 [12.6]	42.5 [12.5]	42.8 [12.5]	42.1 [12.3]	41.6 [12.2]	
	Power	2.8	2.9	2.9	3.1	3.2	3.3	3.4	3.5	3.6	

IDB —Indoor air dry bulb

[ ] Designates Metric Conversions

## HEATING PERFORMANCE DATA – TZHH4-A060

IDB		60°F [15.5°C]			70°F [21.1°C]			80°F [26.7°C]			
		CFM [L/s]	2280 [1076]	1900 [897]	1520 [717]	2280 [1076]	1900 [897]	1520 [717]	2280 [1076]	1900 [897]	1520 [717]
O U T D O O R  D R Y  B U L B  T E M P E R A T U R E  ° F [ ° C]	0 [-17.8]	Total BTUH [kW] Power	22.6 [6.6] 2.8	22.3 [6.5] 2.9	22.0 [6.4] 3.0	21.4 [6.3] 3.3	21.1 [6.2] 3.4	20.8 [6.1] 3.5	20.1 [5.9] 3.8	19.8 [5.8] 3.9	19.5 [5.7] 4.0
	5 [-15]	Total BTUH [kW] Power	26.6 [7.8] 2.9	26.2 [7.7] 3.0	25.8 [7.6] 3.1	25.3 [7.4] 3.4	25.0 [7.3] 3.5	24.6 [7.2] 3.6	24.1 [7.1] 3.9	23.7 [6.9] 4.0	23.4 [6.9] 4.1
	10 [-12.2]	Total BTUH [kW] Power	30.6 [9.0] 3.0	30.1 [8.8] 3.1	29.7 [8.7] 3.1	29.3 [8.6] 3.5	28.9 [8.5] 3.6	28.5 [8.4] 3.7	28.0 [8.2] 4.0	27.6 [8.1] 4.1	27.2 [8.0] 4.2
	15 [-9.4]	Total BTUH [kW] Power	34.5 [10.1] 3.1	34.0 [10.0] 3.1	33.5 [9.8] 3.2	33.3 [9.8] 3.6	32.8 [9.6] 3.7	32.3 [9.5] 3.7	32.0 [9.4] 4.1	31.5 [9.2] 4.2	31.1 [9.1] 4.3
	20 [-6.7]	Total BTUH [kW] Power	38.5 [11.3] 3.1	37.9 [11.1] 3.2	37.4 [11.0] 3.3	37.2 [10.9] 3.6	36.7 [10.8] 3.7	36.2 [10.6] 3.8	36.0 [10.6] 4.2	35.4 [10.4] 4.3	34.9 [10.2] 4.4
	25 [-3.9]	Total BTUH [kW] Power	42.4 [12.4] 3.2	41.8 [12.3] 3.3	41.2 [12.1] 3.4	41.2 [12.1] 3.7	40.6 [11.9] 3.8	40.0 [11.7] 3.9	39.9 [11.7] 4.3	39.4 [11.5] 4.4	38.8 [11.4] 4.5
	30 [-1.1]	Total BTUH [kW] Power	46.4 [13.6] 3.3	45.8 [13.4] 3.4	45.1 [13.2] 3.5	45.1 [13.2] 3.8	44.5 [13.0] 3.9	43.9 [12.9] 4.0	43.9 [12.9] 4.3	43.3 [12.7] 4.4	42.6 [12.5] 4.6
	35 [1.7]	Total BTUH [kW] Power	50.4 [14.8] 3.4	49.7 [14.6] 3.5	48.9 [14.3] 3.6	49.1 [14.4] 3.9	48.4 [14.2] 4.0	47.7 [14.0] 4.1	47.8 [14.0] 4.4	47.2 [13.8] 4.5	46.5 [13.6] 4.6
	40 [4.4]	Total BTUH [kW] Power	54.3 [15.9] 3.5	53.6 [15.7] 3.6	52.8 [15.5] 3.7	53.1 [15.6] 4.0	52.3 [15.3] 4.1	51.6 [15.1] 4.2	51.8 [15.2] 4.5	51.1 [15.0] 4.6	50.4 [14.8] 4.7
	45 [7.2]	Total BTUH [kW] Power	58.3 [17.1] 3.6	57.5 [16.9] 3.6	56.7 [16.6] 3.7	57.0 [16.7] 4.0	56.2 [16.5] 4.2	55.4 [16.2] 4.3	55.8 [16.4] 4.6	55.0 [16.1] 4.7	54.2 [15.9] 4.8
50 [10]	Total BTUH [kW] Power	62.3 [18.3] 3.6	61.4 [18.0] 3.7	60.5 [17.7] 3.8	61.0 [17.9] 4.1	60.1 [17.6] 4.2	59.3 [17.4] 4.3	59.7 [17.5] 4.7	58.9 [17.3] 4.8	58.1 [17.0] 4.9	

IDB —Indoor air dry bulb

[ ] Designates Metric Conversions

## HEATING PERFORMANCE DATA – TZHH6-A024JK

		IDB	60°F [15.5°C]			70°F [21.1°C]			80°F [26.7°C]		
			CFM [L/s]	1200 [566]	900 [453]	800 [378]	1200 [566]	900 [453]	800 [378]	1200 [566]	900 [453]
OUTDOOR DRY BULB TEMPERATURE °F [°C]	0 [-17.8]	Total BTUH [kW]	7.2 [2.1]	7.0 [2.1]	7.0 [2.1]	6.2 [1.8]	6.1 [1.8]	6.0 [1.8]	5.2 [1.5]	5.1 [1.5]	5.1 [1.5]
		Power	1.2	1.3	1.3	1.4	1.4	1.5	1.5	1.6	1.6
	5 [-15]	Total BTUH [kW]	9.1 [2.7]	8.9 [2.6]	8.8 [2.6]	8.1 [2.4]	7.9 [2.3]	7.9 [2.3]	7.1 [2.1]	6.9 [2.0]	6.9 [2.0]
		Power	1.3	1.3	1.3	1.4	1.5	1.5	1.6	1.6	1.7
	10 [-12.2]	Total BTUH [kW]	11.0 [3.2]	10.7 [3.1]	10.7 [3.1]	10.0 [2.9]	9.8 [2.9]	9.7 [2.8]	9.0 [2.6]	8.8 [2.6]	8.7 [2.5]
		Power	1.3	1.3	1.4	1.4	1.5	1.5	1.6	1.7	1.7
	15 [-9.4]	Total BTUH [kW]	12.9 [3.8]	12.6 [3.7]	12.5 [3.7]	11.9 [3.5]	11.6 [3.4]	11.5 [3.4]	10.9 [3.2]	10.7 [3.1]	10.6 [3.1]
		Power	1.3	1.4	1.4	1.5	1.5	1.5	1.6	1.7	1.7
	20 [-6.7]	Total BTUH [kW]	14.8 [4.3]	14.4 [4.2]	14.3 [4.2]	13.8 [4.0]	13.5 [4.0]	13.4 [3.9]	12.8 [3.8]	12.5 [3.7]	12.4 [3.6]
		Power	1.3	1.4	1.4	1.5	1.5	1.6	1.6	1.7	1.7
25 [-3.9]	Total BTUH [kW]	16.7 [4.9]	16.3 [4.8]	16.2 [4.7]	15.7 [4.6]	15.3 [4.5]	15.2 [4.5]	14.7 [4.3]	14.4 [4.2]	14.2 [4.2]	
	Power	1.4	1.4	1.5	1.5	1.6	1.6	1.7	1.7	1.8	
30 [-1.1]	Total BTUH [kW]	18.6 [5.5]	18.2 [5.3]	18.0 [5.3]	17.6 [5.2]	17.2 [5.0]	17.0 [5.0]	16.6 [4.9]	16.2 [4.7]	16.1 [4.7]	
	Power	1.4	1.5	1.5	1.5	1.6	1.6	1.7	1.8	1.8	
35 [1.7]	Total BTUH [kW]	20.5 [6.0]	20.0 [5.9]	19.9 [5.8]	19.5 [5.7]	19.0 [5.6]	18.9 [5.5]	18.5 [5.4]	18.1 [5.3]	17.9 [5.2]	
	Power	1.4	1.5	1.5	1.6	1.6	1.7	1.7	1.8	1.8	
40 [4.4]	Total BTUH [kW]	22.4 [6.6]	21.9 [6.4]	21.7 [6.4]	21.4 [6.3]	20.9 [6.1]	20.7 [6.1]	20.4 [6.0]	19.9 [5.8]	19.8 [5.8]	
	Power	1.5	1.5	1.5	1.6	1.7	1.7	1.7	1.8	1.9	
45 [7.2]	Total BTUH [kW]	24.3 [7.1]	23.7 [6.9]	23.5 [6.9]	23.3 [6.8]	22.7 [6.7]	22.6 [6.6]	22.3 [6.5]	21.8 [6.4]	21.6 [6.3]	
	Power	1.5	1.5	1.6	1.6	1.7	1.7	1.8	1.9	1.9	
50 [10]	Total BTUH [kW]	26.2 [7.7]	25.6 [7.5]	25.4 [7.4]	25.2 [7.4]	24.6 [7.2]	24.4 [7.2]	24.2 [7.1]	23.6 [6.9]	23.4 [6.9]	
	Power	1.5	1.6	1.6	1.6	1.7	1.7	1.8	1.9	1.9	

IDB —Indoor air dry bulb

## HEATING PERFORMANCE DATA – TZHH6-A030JK

		IDB	60°F [15.5°C]			70°F [21.1°C]			80°F [26.7°C]		
			CFM [L/s]	1200 [566]	1000 [472]	800 [378]	1200 [566]	1000 [472]	800 [378]	1200 [566]	1000 [472]
OUTDOOR DRY BULB TEMPERATURE °F [°C]	0 [-17.8]	Total BTUH [kW]	9.3 [2.7]	9.2 [2.7]	9.0 [2.6]	8.4 [2.5]	8.3 [2.4]	8.2 [2.4]	7.5 [2.2]	7.4 [2.2]	7.3 [2.1]
		Power	1.5	1.5	1.6	1.6	1.7	1.7	1.9	1.9	2.0
	5 [-15]	Total BTUH [kW]	11.5 [3.4]	11.3 [3.3]	11.1 [3.3]	10.6 [3.1]	10.4 [3.0]	10.3 [3.0]	9.7 [2.8]	9.5 [2.8]	9.4 [2.8]
		Power	1.5	1.6	1.6	1.7	1.7	1.8	1.9	2.0	2.0
	10 [-12.2]	Total BTUH [kW]	13.6 [4.0]	13.4 [3.9]	13.2 [3.9]	12.7 [3.7]	12.6 [3.7]	12.4 [3.6]	11.8 [3.5]	11.7 [3.4]	11.5 [3.4]
		Power	1.6	1.6	1.6	1.7	1.7	1.8	1.9	2.0	2.0
	15 [-9.4]	Total BTUH [kW]	15.8 [4.6]	15.6 [4.6]	15.4 [4.5]	14.9 [4.4]	14.7 [4.3]	14.5 [4.2]	14.0 [4.1]	13.8 [4.0]	13.6 [4.0]
		Power	1.6	1.6	1.7	1.7	1.8	1.8	2.0	2.0	2.1
	20 [-6.7]	Total BTUH [kW]	18.0 [5.3]	17.7 [5.2]	17.5 [5.1]	17.1 [5.0]	16.8 [4.9]	16.6 [4.9]	16.2 [4.7]	15.9 [4.7]	15.7 [4.6]
		Power	1.6	1.7	1.7	1.8	1.8	1.9	2.0	2.1	2.1
25 [-3.9]	Total BTUH [kW]	20.1 [5.9]	19.9 [5.8]	19.6 [5.7]	19.2 [5.6]	19.0 [5.6]	18.7 [5.5]	18.3 [5.4]	18.1 [5.3]	17.8 [5.2]	
	Power	1.7	1.7	1.7	1.8	1.8	1.9	2.0	2.1	2.2	
30 [-1.1]	Total BTUH [kW]	22.3 [6.5]	22.0 [6.4]	21.7 [6.4]	21.4 [6.3]	21.1 [6.2]	20.8 [6.1]	20.5 [6.0]	20.2 [5.9]	19.9 [5.8]	
	Power	1.7	1.7	1.8	1.8	1.9	1.9	2.1	2.1	2.2	
35 [1.7]	Total BTUH [kW]	24.5 [7.2]	24.1 [7.1]	23.8 [7.0]	23.6 [6.9]	23.3 [6.8]	22.9 [6.7]	22.7 [6.7]	22.4 [6.6]	22.0 [6.4]	
	Power	1.7	1.8	1.8	1.9	1.9	2.0	2.1	2.2	2.2	
40 [4.4]	Total BTUH [kW]	26.6 [7.8]	26.3 [7.7]	25.9 [7.6]	25.8 [7.6]	25.4 [7.4]	25.0 [7.3]	24.9 [7.3]	24.5 [7.2]	24.2 [7.1]	
	Power	1.8	1.8	1.8	1.9	1.9	2.0	2.1	2.2	2.3	
45 [7.2]	Total BTUH [kW]	28.8 [8.4]	28.4 [8.3]	28.0 [8.2]	27.9 [8.2]	27.5 [8.1]	27.1 [7.9]	27.0 [7.9]	26.6 [7.8]	26.3 [7.7]	
	Power	1.8	1.8	1.9	1.9	2.0	2.0	2.2	2.2	2.3	
50 [10]	Total BTUH [kW]	31.0 [9.1]	30.6 [9.0]	30.1 [8.8]	30.1 [8.8]	29.7 [8.7]	29.2 [8.6]	29.2 [8.6]	28.8 [8.4]	28.4 [8.3]	
	Power	1.8	1.9	1.9	2.0	2.0	2.1	2.2	2.3	2.3	

IDB —Indoor air dry bulb

[ ] Designates Metric Conversions

## HEATING PERFORMANCE DATA—TZHH6-A036JK

IDB		60°F [15.5°C]			70°F [21.1°C]			80°F [26.7°C]			
		CFM [L/s]	1440 [680]	1200 [566]	960 [453]	1440 [680]	1200 [566]	960 [453]	1440 [680]	1200 [566]	960 [453]
OUTDOOR DRY BULB TEMPERATURE °F [°C]	0 [-17.8]	Total BTUH [kW] Power	11.0 [3.2] 1.7	10.9 [3.2] 1.8	10.7 [3.1] 1.8	10.0 [2.9] 1.9	9.8 [2.9] 2.0	9.7 [2.8] 2.0	9.0 [2.6] 2.3	8.8 [2.6] 2.4	8.7 [2.5] 2.5
	5 [-15]	Total BTUH [kW] Power	13.5 [4.0] 1.8	13.3 [3.9] 1.8	13.1 [3.8] 1.9	12.4 [3.6] 2.0	12.3 [3.6] 2.0	12.1 [3.5] 2.1	11.4 [3.3] 2.4	11.2 [3.3] 2.4	11.1 [3.3] 2.5
	10 [-12.2]	Total BTUH [kW] Power	15.9 [4.7] 1.8	15.7 [4.6] 1.9	15.5 [4.5] 1.9	14.9 [4.4] 2.0	14.7 [4.3] 2.1	14.5 [4.2] 2.2	13.9 [4.1] 2.4	13.7 [4.0] 2.5	13.5 [4.0] 2.6
	15 [-9.4]	Total BTUH [kW] Power	18.4 [5.4] 1.9	18.1 [5.3] 1.9	17.9 [5.2] 2.0	17.4 [5.1] 2.1	17.1 [5.0] 2.1	16.9 [5.0] 2.2	16.3 [4.8] 2.5	16.1 [4.7] 2.5	15.9 [4.7] 2.6
	20 [-6.7]	Total BTUH [kW] Power	20.9 [6.1] 1.9	20.6 [6.0] 2.0	20.3 [5.9] 2.0	19.8 [5.8] 2.1	19.5 [5.7] 2.2	19.3 [5.7] 2.3	18.8 [5.5] 2.5	18.5 [5.4] 2.6	18.3 [5.4] 2.7
	25 [-3.9]	Total BTUH [kW] Power	23.3 [6.8] 2.0	23.0 [6.7] 2.0	22.7 [6.7] 2.1	22.3 [6.5] 2.2	22.0 [6.4] 2.2	21.7 [6.4] 2.3	21.2 [6.2] 2.6	20.9 [6.1] 2.6	20.6 [6.0] 2.7
	30 [-1.1]	Total BTUH [kW] Power	25.8 [7.6] 2.0	25.4 [7.4] 2.1	25.1 [7.4] 2.1	24.7 [7.2] 2.2	24.4 [7.2] 2.3	24.0 [7.0] 2.4	23.7 [6.9] 2.6	23.4 [6.9] 2.7	23.0 [6.7] 2.8
	35 [1.7]	Total BTUH [kW] Power	28.2 [8.3] 2.1	27.8 [8.1] 2.1	27.4 [8.0] 2.2	27.2 [8.0] 2.3	26.8 [7.9] 2.3	26.4 [7.7] 2.4	26.2 [7.7] 2.7	25.8 [7.6] 2.7	25.4 [7.4] 2.8
	40 [4.4]	Total BTUH [kW] Power	30.7 [9.0] 2.1	30.3 [8.9] 2.2	29.8 [8.7] 2.2	29.7 [8.7] 2.3	29.2 [8.6] 2.4	28.8 [8.4] 2.5	28.6 [8.4] 2.7	28.2 [8.3] 2.8	27.8 [8.1] 2.9
	45 [7.2]	Total BTUH [kW] Power	33.2 [9.7] 2.2	32.7 [9.6] 2.2	32.2 [9.4] 2.3	32.1 [9.4] 2.4	31.7 [9.3] 2.4	31.2 [9.1] 2.5	31.1 [9.1] 2.8	30.6 [9.0] 2.8	30.2 [8.9] 2.9
50 [10]	Total BTUH [kW] Power	35.6 [10.4] 2.2	35.1 [10.3] 2.3	34.6 [10.1] 2.3	34.6 [10.1] 2.4	34.1 [10.0] 2.5	33.6 [9.8] 2.6	33.5 [9.8] 2.8	33.1 [9.7] 2.9	32.6 [9.6] 3.0	

IDB —Indoor air dry bulb

## HEATING PERFORMANCE DATA—TZHH6-A042JK

IDB		60°F [15.5°C]			70°F [21.1°C]			80°F [26.7°C]			
		CFM [L/s]	1860 [878]	1425 [673]	1240 [585]	1860 [878]	1425 [673]	1240 [585]	1860 [878]	1425 [673]	1240 [585]
OUTDOOR DRY BULB TEMPERATURE °F [°C]	0 [-17.8]	Total BTUH [kW] Power	12.9 [3.8] 2.0	12.6 [3.7] 2.0	12.5 [3.7] 2.1	11.7 [3.4] 2.2	11.5 [3.4] 2.3	11.4 [3.3] 2.3	10.6 [3.1] 2.5	10.3 [3.0] 2.6	10.3 [3.0] 2.6
	5 [-15]	Total BTUH [kW] Power	15.8 [4.6] 2.0	15.5 [4.5] 2.1	15.3 [4.5] 2.1	14.7 [4.3] 2.2	14.4 [4.2] 2.3	14.2 [4.2] 2.4	13.5 [4.0] 2.5	13.2 [3.9] 2.6	13.1 [3.8] 2.7
	10 [-12.2]	Total BTUH [kW] Power	18.8 [5.5] 2.0	18.4 [5.4] 2.1	18.2 [5.3] 2.2	17.6 [5.2] 2.3	17.3 [5.1] 2.4	17.1 [5.0] 2.4	16.5 [4.8] 2.6	16.1 [4.7] 2.7	16.0 [4.7] 2.7
	15 [-9.4]	Total BTUH [kW] Power	21.7 [6.4] 2.1	21.3 [6.2] 2.2	21.1 [6.2] 2.2	20.6 [6.0] 2.3	20.2 [5.9] 2.4	20.0 [5.9] 2.4	19.5 [5.7] 2.6	19.0 [5.6] 2.7	18.9 [5.5] 2.7
	20 [-6.7]	Total BTUH [kW] Power	24.7 [7.2] 2.1	24.2 [7.1] 2.2	23.9 [7.0] 2.2	23.6 [6.9] 2.3	23.1 [6.8] 2.4	22.8 [6.7] 2.5	22.4 [6.6] 2.6	21.9 [6.4] 2.7	21.7 [6.4] 2.8
	25 [-3.9]	Total BTUH [kW] Power	27.7 [8.1] 2.2	27.1 [7.9] 2.2	26.8 [7.9] 2.3	26.5 [7.8] 2.4	26.0 [7.6] 2.5	25.7 [7.5] 2.5	25.4 [7.4] 2.7	24.8 [7.3] 2.8	24.6 [7.2] 2.8
	30 [-1.1]	Total BTUH [kW] Power	30.6 [9.0] 2.2	30.0 [8.8] 2.3	29.7 [8.7] 2.3	29.5 [8.6] 2.4	28.9 [8.5] 2.5	28.6 [8.4] 2.6	28.3 [8.3] 2.7	27.7 [8.1] 2.8	27.5 [8.1] 2.9
	35 [1.7]	Total BTUH [kW] Power	33.6 [9.8] 2.2	32.9 [9.6] 2.3	32.6 [9.6] 2.4	32.4 [9.5] 2.5	31.8 [9.3] 2.6	31.5 [9.2] 2.6	31.3 [9.2] 2.7	30.6 [9.0] 2.9	30.3 [8.9] 2.9
	40 [4.4]	Total BTUH [kW] Power	36.5 [10.7] 2.3	35.8 [10.5] 2.4	35.4 [10.4] 2.4	35.4 [10.4] 2.5	34.6 [10.1] 2.6	34.3 [10.1] 2.6	34.3 [10.1] 2.8	33.5 [9.8] 2.9	33.2 [9.7] 2.9
	45 [7.2]	Total BTUH [kW] Power	39.5 [11.6] 2.3	38.7 [11.3] 2.4	38.3 [11.2] 2.4	38.4 [11.3] 2.5	37.5 [11.0] 2.6	37.2 [10.9] 2.7	37.2 [10.9] 2.8	36.4 [10.7] 2.9	36.1 [10.6] 3.0
50 [10]	Total BTUH [kW] Power	42.5 [12.5] 2.4	41.6 [12.2] 2.4	41.2 [12.1] 2.5	41.3 [12.1] 2.6	40.4 [11.8] 2.7	40.1 [11.8] 2.7	40.2 [11.8] 2.9	39.3 [11.5] 3.0	39.0 [11.4] 3.0	

IDB —Indoor air dry bulb

[ ] Designates Metric Conversions

## HEATING PERFORMANCE DATA – TZHH6-A048JK

		IDB	60°F [15.5°C]			70°F [21.1°C]			80°F [26.7°C]		
			CFM [L/s]	1860 [878]	1525 [720]	1240 [585]	1860 [878]	1525 [720]	1240 [585]	1860 [878]	1525 [720]
OUTDOOR DRY BULB TEMPERATURE °F [°C]	0 [-17.8]	Total BTUH [kW] Power	12.7 [3.7] 2.0	12.5 [3.7] 2.0	12.3 [3.6] 2.1	11.5 [3.4] 2.2	11.3 [3.3] 2.3	11.2 [3.3] 2.3	10.3 [3.0] 2.6	10.2 [3.0] 2.7	10.0 [2.9] 2.7
	5 [-15]	Total BTUH [kW] Power	16.1 [4.7] 2.0	15.8 [4.6] 2.1	15.6 [4.6] 2.1	14.9 [4.4] 2.3	14.6 [4.3] 2.3	14.4 [4.2] 2.4	13.7 [4.0] 2.6	13.5 [4.0] 2.7	13.3 [3.9] 2.8
	10 [-12.2]	Total BTUH [kW] Power	19.4 [5.7] 2.1	19.1 [5.6] 2.1	18.9 [5.5] 2.2	18.2 [5.3] 2.3	18.0 [5.3] 2.4	17.7 [5.2] 2.5	17.1 [5.0] 2.7	16.8 [4.9] 2.8	16.6 [4.9] 2.8
	15 [-9.4]	Total BTUH [kW] Power	22.8 [6.7] 2.2	22.4 [6.6] 2.2	22.1 [6.5] 2.3	21.6 [6.3] 2.4	21.3 [6.2] 2.5	21.0 [6.2] 2.5	20.4 [6.0] 2.8	20.1 [5.9] 2.8	19.8 [5.8] 2.9
	20 [-6.7]	Total BTUH [kW] Power	26.1 [7.6] 2.2	25.7 [7.5] 2.3	25.4 [7.4] 2.3	25.0 [7.3] 2.5	24.6 [7.2] 2.5	24.3 [7.1] 2.6	23.8 [7.0] 2.8	23.4 [6.9] 2.9	23.1 [6.8] 3.0
	25 [-3.9]	Total BTUH [kW] Power	29.5 [8.6] 2.3	29.1 [8.5] 2.3	28.7 [8.4] 2.4	28.3 [8.3] 2.5	27.9 [8.2] 2.6	27.5 [8.1] 2.7	27.1 [7.9] 2.9	26.7 [7.8] 3.0	26.4 [7.7] 3.0
	30 [-1.1]	Total BTUH [kW] Power	32.9 [9.6] 2.3	32.4 [9.5] 2.4	31.9 [9.3] 2.5	31.7 [9.3] 2.6	31.2 [9.1] 2.7	30.8 [9.0] 2.7	30.5 [8.9] 3.0	30.0 [8.8] 3.0	29.6 [8.7] 3.1
	35 [1.7]	Total BTUH [kW] Power	36.2 [10.6] 2.4	35.7 [10.5] 2.5	35.2 [10.3] 2.5	35.1 [10.3] 2.7	34.5 [10.1] 2.7	34.1 [10.0] 2.8	33.9 [9.9] 3.0	33.4 [9.8] 3.1	32.9 [9.6] 3.2
	40 [4.4]	Total BTUH [kW] Power	39.6 [11.6] 2.5	39.0 [11.4] 2.5	38.5 [11.3] 2.6	38.4 [11.3] 2.7	37.8 [11.1] 2.8	37.3 [10.9] 2.9	37.2 [10.9] 3.1	36.7 [10.8] 3.2	36.2 [10.6] 3.2
	45 [7.2]	Total BTUH [kW] Power	43.0 [12.6] 2.5	42.3 [12.4] 2.6	41.7 [12.2] 2.7	41.8 [12.3] 2.8	41.1 [12.0] 2.9	40.6 [11.9] 2.9	40.6 [11.9] 3.1	40.0 [11.7] 3.2	39.4 [11.5] 3.3
50 [10]	Total BTUH [kW] Power	46.3 [13.6] 2.6	45.6 [13.4] 2.7	45.0 [13.2] 2.7	45.2 [13.2] 2.8	44.5 [13.0] 2.9	43.9 [12.9] 3.0	44.0 [12.9] 3.2	43.3 [12.7] 3.3	42.7 [12.5] 3.4	

IDB —Indoor air dry bulb

## HEATING PERFORMANCE DATA – TZHH6-A060JK

		IDB	60°F [15.5°C]			70°F [21.1°C]			80°F [26.7°C]		
			CFM [L/s]	1860 [878]	1900 [897]	1240 [585]	1860 [878]	1900 [897]	1240 [585]	1860 [878]	1900 [897]
OUTDOOR DRY BULB TEMPERATURE °F [°C]	0 [-17.8]	Total BTUH [kW] Power	18.6 [5.5] 2.6	18.6 [5.5] 2.6	18.2 [5.3] 2.7	17.5 [5.1] 3.0	17.5 [5.1] 3.0	17.1 [5.0] 3.1	16.3 [4.8] 3.4	16.3 [4.8] 3.4	15.9 [4.7] 3.5
	5 [-15]	Total BTUH [kW] Power	22.4 [6.6] 2.7	22.5 [6.6] 2.7	21.9 [6.4] 2.8	21.3 [6.2] 3.1	21.3 [6.2] 3.1	20.8 [6.1] 3.2	20.1 [5.9] 3.5	20.2 [5.9] 3.5	19.7 [5.8] 3.6
	10 [-12.2]	Total BTUH [kW] Power	26.3 [7.7] 2.8	26.3 [7.7] 2.8	25.7 [7.5] 2.9	25.1 [7.4] 3.2	25.2 [7.4] 3.2	24.5 [7.2] 3.3	24.0 [7.0] 3.6	24.0 [7.0] 3.6	23.4 [6.9] 3.7
	15 [-9.4]	Total BTUH [kW] Power	30.1 [8.8] 2.9	30.1 [8.8] 2.9	29.4 [8.6] 3.0	29.0 [8.5] 3.3	29.0 [8.5] 3.3	28.3 [8.3] 3.4	27.8 [8.1] 3.7	27.8 [8.1] 3.6	27.1 [7.9] 3.8
	20 [-6.7]	Total BTUH [kW] Power	33.9 [9.9] 3.0	34.0 [10.0] 3.0	33.1 [9.7] 3.1	32.8 [9.6] 3.4	32.8 [9.6] 3.4	32.0 [9.4] 3.5	31.6 [9.3] 3.7	31.7 [9.3] 3.7	30.9 [9.1] 3.9
	25 [-3.9]	Total BTUH [kW] Power	37.8 [11.1] 3.1	37.8 [11.1] 3.1	36.9 [10.8] 3.2	36.6 [10.7] 3.4	36.7 [10.8] 3.4	35.8 [10.5] 3.6	35.5 [10.4] 3.8	35.5 [10.4] 3.8	34.6 [10.1] 4.0
	30 [-1.1]	Total BTUH [kW] Power	41.6 [12.2] 3.2	41.7 [12.2] 3.2	40.6 [11.9] 3.3	40.4 [11.8] 3.5	40.5 [11.9] 3.5	39.5 [11.6] 3.7	39.3 [11.5] 3.9	39.3 [11.5] 3.9	38.4 [11.3] 4.1
	35 [1.7]	Total BTUH [kW] Power	45.4 [13.3] 3.3	45.5 [13.3] 3.2	44.4 [13.0] 3.4	44.3 [13.0] 3.6	44.3 [13.0] 3.6	43.2 [12.7] 3.8	43.1 [12.6] 4.0	43.2 [12.7] 4.0	42.1 [12.3] 4.2
	40 [4.4]	Total BTUH [kW] Power	49.2 [14.4] 3.3	49.3 [14.4] 3.3	48.1 [14.1] 3.5	48.1 [14.1] 3.7	48.2 [14.1] 3.7	47.0 [13.8] 3.9	46.9 [13.7] 4.1	47.0 [13.8] 4.1	45.8 [13.4] 4.3
	45 [7.2]	Total BTUH [kW] Power	53.1 [15.6] 3.4	53.2 [15.6] 3.4	51.8 [15.2] 3.6	51.9 [15.2] 3.8	52.0 [15.2] 3.8	50.7 [14.9] 4.0	50.8 [14.9] 4.2	50.8 [14.9] 4.2	49.6 [14.5] 4.4
50 [10]	Total BTUH [kW] Power	56.9 [16.7] 3.5	57.0 [16.7] 3.5	55.6 [16.3] 3.7	55.8 [16.4] 3.9	55.8 [16.4] 3.9	54.5 [16.0] 4.1	54.6 [16.0] 4.3	54.7 [16.0] 4.3	53.3 [15.6] 4.5	

IDB —Indoor air dry bulb

[ ] Designates Metric Conversions

# INDOOR AIRFLOW PERFORMANCE — 208/230 VOLTS

Nominal Cooling Capacity Tons [kW]	Motor Speed from Factory	Manufacturer Recommended Air-Flow Range CFM		Blower Size/ Motor HP [W] # of Speed	Voltage	Motor Speed	CFM Air Delivery/RPM/Watts										
		Min.	Max.				External Static Pressure—Inches W.C. [kPa]										
							0.1 [0.02]	0.2 [0.05]	0.3 [0.07]	0.4 [0.10]	0.5 [0.12]	0.6 [0.15]	0.7 [0.17]	0.8 [0.20]	0.9 [0.22]	1.0 [0.25]	
2.0 [7.03]	Low (Tap 2) X13 (ECM Motor)	700	900	10x9 1/2 hp [373] 2 Speed	208	Low (Tap 2)	CFM	959 [453]	892 [421]	825 [389]	758 [358]	691 [326]	624 [294]	557 [263]	491 [232]	—	—
							RPM	582	606	655	723	808	851	906	996	—	—
							Watts	132	110	96	106	119	123	132	144	—	—
	High (Tap 1)	CFM	1229 [580]			1170 [552]	1112 [525]	1054 [497]	996 [470]	938 [443]	879 [415]	821 [387]	763 [360]	705 [333]			
		RPM	607			634	698	761	815	880	946	989	1038	1091			
		Watts	161			145	159	173	182	196	210	220	231	237			
2.5 [8.79]	Low (Tap 2) X13 (ECM Motor)	875	1125	10x9 1/2 hp [373] 2 Speed	208	Low (Tap 2)	CFM	1162 [548]	1099 [519]	1035 [488]	972 [459]	908 [429]	844 [398]	781 [369]	717 [338]	654 [309]	590 [278]
							RPM	603	626	690	752	815	896	941	984	1027	1096
							Watts	143	124	136	148	157	175	180	188	192	202
	High (Tap 1)	CFM	1306 [616]			1253 [591]	1200 [566]	1147 [541]	1095 [517]	1042 [492]	989 [467]	937 [442]	884 [417]	831 [392]			
		RPM	632			679	733	787	841	883	941	1035	1067	1099			
		Watts	174			187	201	215	227	235	248	266	273	277			
3.0 [10.55]	Low (Tap 2) X13 (ECM Motor)	1050	1350	10x9 1/2 hp [373] 2 Speed	230	Low (Tap 2)	CFM	1169 [552]	1109 [523]	1049 [495]	988 [466]	928 [438]	868 [410]	807 [381]	747 [353]	687 [324]	626 [295]
							RPM	603	619	693	756	809	893	942	989	1034	1076
							Watts	144	130	138	151	159	174	185	195	199	209
	High (Tap 1)	CFM	1365 [644]			1316 [621]	1266 [597]	1217 [574]	1168 [551]	1119 [528]	1069 [505]	1020 [481]	971 [458]	922 [435]			
		RPM	631			677	732	784	843	894	942	1035	1077	1118			
		Watts	177			190	204	218	234	247	256	279	289	294			
3.0 [10.55]	Low (Tap 2) X13 (ECM Motor)	1050	1350	10x9 1/2 hp [373] 2 Speed	208	Low (Tap 2)	CFM	1328 [627]	1276 [602]	1223 [577]	1171 [553]	1118 [528]	1066 [503]	1013 [478]	961 [454]	—	—
							RPM	642	693	747	803	852	903	988	1031	—	—
							Watts	173	187	200	214	226	238	254	263	—	—
	High (Tap 1)	CFM	1508 [712]			1459 [689]	1409 [665]	1359 [641]	1310 [618]	1260 [595]	1210 [571]	1160 [547]	1111 [524]	1061 [501]			
		RPM	698			738	789	839	888	933	983	1035	1103	1137			
		Watts	243			255	271	285	299	310	322	332	343	343			
3.0 [10.55]	Low (Tap 2) X13 (ECM Motor)	1050	1350	10x9 1/2 hp [373] 2 Speed	230	Low (Tap 2)	CFM	1328 [627]	1280 [604]	1231 [581]	1183 [558]	1135 [536]	1086 [513]	1038 [490]	990 [467]	941 [444]	893 [421]
							RPM	648	697	752	807	857	903	989	1036	1077	1114
							Watts	178	191	206	220	233	246	265	277	286	291
	High (Tap 1)	CFM	1510 [713]			1464 [691]	1418 [669]	1373 [648]	1327 [626]	1281 [605]	1235 [583]	1190 [562]	1144 [540]	1098 [518]			
		RPM	707			743	792	841	890	941	981	1031	1114	1151			
		Watts	248			261	277	292	307	322	334	348	366	358			

[ ] Designates Metric Conversions



**INDOOR AIRFLOW PERFORMANCE -- 208/230 VOLTS**

Nominal Cooling Capacity Tons [kW]	Motor Speed from Factory	Manufacturer Recommended Air-Flow Range CFM		Blower Size/ Motor HP [W] # of Speed	Voltage	Motor Speed	CFM Air Delivery/RPM/Watts										
		Min.	Max.				External Static Pressure—Inches W.C. [kPa]										
							0.1 [0.2]	0.2 [0.05]	0.3 [0.07]	0.4 [0.10]	0.5 [0.12]	0.6 [0.15]	0.7 [0.17]	0.8 [0.20]	0.9 [0.22]	1.0 [0.25]	
3.5 [12.31]	Low (Tap 2) X13 (ECM Motor)	1225	1575	11x9 3/4 hp [559] 2 Speed	208	Low (Tap 2)	CFM	1531 [726]	1477 [697]	1423 [672]	1370 [647]	1316 [621]	1262 [596]	1208 [570]	1154 [545]	1101 [520]	1047 [494]
							RPM	602	619	668	715	757	801	844	878	918	954
							Watts	238	227	236	251	266	281	296	307	320	333
	High (Tap 1)	1575	11x9 3/4 hp [559] 2 Speed	208	High (Tap 1)	CFM	1724 [814]	1678 [792]	1632 [770]	1586 [749]	1540 [727]	1495 [706]	1449 [684]	1403 [662]	1357 [640]	1311 [619]	1266 [598]
						RPM	639	671	715	759	794	834	875	911	948	977	
						Watts	295	309	330	348	363	380	397	414	429	440	
4.0 [14.07]	Low (Tap 2) X13 (ECM Motor)	1400	1800	11x9 3/4 hp [559] 2 Speed	230	Low (Tap 2)	CFM	1542 [728]	1490 [703]	1438 [679]	1386 [654]	1335 [630]	1283 [606]	1231 [581]	1180 [557]	1128 [532]	1076 [508]
							RPM	598	617	662	714	758	800	849	876	913	951
							Watts	244	231	237	254	270	285	304	313	326	340
	High (Tap 1)	1800	11x9 3/4 hp [559] 2 Speed	230	High (Tap 1)	CFM	1740 [821]	1695 [800]	1649 [778]	1604 [757]	1558 [735]	1513 [714]	1467 [692]	1422 [671]	1376 [649]	1331 [628]	1287 [607]
						RPM	632	665	709	749	797	833	879	917	951	981	
						Watts	295	311	331	350	371	386	409	426	440	454	
5.0 [17.6]	Low (Tap 2) X13 (ECM Motor)	1750	2250	11x9 1 hp [746] 2 Speed	208	Low (Tap 2)	CFM	1708 [806]	1658 [782]	1609 [759]	1559 [736]	1510 [713]	1460 [689]	1410 [665]	1361 [642]	1311 [619]	1262 [596]
							RPM	619	651	686	741	783	822	859	894	937	971
							Watts	280	284	298	323	339	355	370	385	402	415
	High (Tap 1)	2250	11x9 1 hp [746] 2 Speed	208	High (Tap 1)	CFM	1917 [905]	1872 [883]	1827 [862]	1782 [841]	1736 [819]	1691 [798]	1646 [777]	1601 [756]	1556 [734]	1510 [713]	1465 [692]
						RPM	673	702	736	769	818	860	898	928	960	989	
						Watts	377	392	409	426	451	473	490	504	518	531	
5.0 [17.6]	Low (Tap 2) X13 (ECM Motor)	1750	2250	11x9 1 hp [746] 2 Speed	230	Low (Tap 2)	CFM	1701 [803]	1655 [781]	1609 [759]	1563 [738]	1517 [716]	1471 [694]	1425 [673]	1379 [651]	1333 [629]	1287 [607]
							RPM	624	648	696	743	787	826	863	895	934	970
							Watts	280	287	309	328	347	363	380	392	410	426
	High (Tap 1)	2250	11x9 1 hp [746] 2 Speed	230	High (Tap 1)	CFM	1921 [907]	1878 [886]	1835 [866]	1792 [846]	1749 [825]	1706 [805]	1663 [785]	1620 [765]	1577 [744]	1534 [724]	1491 [704]
						RPM	678	706	738	776	816	865	899	932	967	994	
						Watts	385	400	416	439	458	484	501	517	537	550	
5.0 [17.6]	Low (Tap 2) X13 (ECM Motor)	1750	2250	11x9 1 hp [746] 2 Speed	208	Low (Tap 2)	CFM	1954 [922]	1914 [903]	1874 [884]	1833 [865]	1793 [846]	1753 [827]	1713 [808]	1673 [790]	1632 [770]	1592 [751]
							RPM	719	747	779	818	857	894	928	963	998	1038
							Watts	439	451	469	491	512	534	553	573	590	611
	High (Tap 1)	2250	11x9 1 hp [746] 2 Speed	208	High (Tap 1)	CFM	2173 [1026]	2136 [1008]	2098 [990]	2061 [973]	2024 [955]	1986 [937]	1949 [920]	1911 [902]	1874 [884]	1837 [867]	
						RPM	775	803	830	860	896	928	959	988	1019	1050	
						Watts	604	622	642	663	686	706	727	745	765	784	
5.0 [17.6]	Low (Tap 2) X13 (ECM Motor)	1750	2250	11x9 1 hp [746] 2 Speed	230	Low (Tap 2)	CFM	1986 [937]	1945 [918]	1905 [899]	1864 [880]	1823 [860]	1782 [841]	1741 [822]	1700 [802]	1659 [783]	1618 [764]
							RPM	731	759	792	832	871	909	943	979	1014	1055
							Watts	446	458	477	499	521	543	562	582	600	621
	High (Tap 1)	2250	11x9 1 hp [746] 2 Speed	230	High (Tap 1)	CFM	2229 [1052]	2190 [1034]	2152 [1016]	2114 [998]	2075 [979]	2037 [961]	1999 [943]	1960 [925]	1922 [907]	1884 [889]	
						RPM	795	824	851	882	919	952	983	1013	1045	1077	
						Watts	619	638	658	680	703	724	745	764	784	804	

[ ] Designates Metric Conversions

# INDOOR AIRFLOW PERFORMANCE — 208/240 VOLTS

Model	Motor Speed from Factory	Recommended Airflow Range		Voltage	Motor Speed (Tap Setting)	External Static Pressure—Inches W.C. [kPa]													
		Min	Max			0.1 [1.02]	0.2 [1.05]	0.3 [1.07]	0.4 [1.10]	0.5 [1.12]	0.6 [1.15]	0.7 [1.17]	0.8 [1.20]	0.9 [1.22]	1.0 [1.25]				
TZHH6-A024J	2 X13 (ECM Motor)	700	900	208	Low Speed (Tap 2)	CFM	1070 [505]	960 [453]	860 [406]	760 [359]	680 [321]	610 [288]	550 [260]	—	—	—	—		
					Watts	106	105	105	108	112	118	127	—	—	—	—			
	High Speed (Tap 1)	CFM	1210 [571]	1160 [548]	1110 [524]	1050 [496]	1000 [472]	940 [444]	880 [415]	830 [392]	770 [363]	700 [330]	—	—	—	—	—		
	Watts	134	144	154	164	174	185	196	206	217	228	—	—	—	—	—	—		
	Low Speed (Tap 2)	CFM	1080 [510]	960 [453]	860 [406]	770 [363]	690 [326]	620 [293]	570 [269]	—	—	—	—	—	—	—	—	—	
	Watts	110	108	108	110	114	120	129	—	—	—	—	—	—	—	—	—	—	
TZHH6-A030J	2 X13 (ECM Motor)	875	1125	208	Low Speed (Tap 2)	CFM	1260 [595]	1020 [481]	820 [387]	660 [312]	530 [250]	—	—	—	—	—	—		
					Watts	161	125	101	91	93	—	—	—	—	—	—	—	—	—
	High Speed (Tap 1)	CFM	1430 [675]	1340 [632]	1260 [595]	1180 [557]	1110 [524]	1040 [491]	980 [463]	920 [434]	870 [411]	820 [387]	—	—	—	—	—	—	
	Watts	208	208	210	214	221	229	239	251	265	281	—	—	—	—	—	—	—	
	Low Speed (Tap 2)	CFM	1150 [543]	980 [463]	830 [392]	690 [326]	570 [269]	—	—	—	—	—	—	—	—	—	—	—	—
	Watts	161	125	101	91	93	—	—	—	—	—	—	—	—	—	—	—	—	—
TZHH6-A036J	2 X13 (ECM Motor)	1050	1350	230	High Speed (Tap 1)	CFM	1420 [670]	1340 [632]	1260 [595]	1190 [562]	1120 [529]	1060 [500]	1000 [472]	940 [444]	890 [420]	840 [396]	—	—	
					Watts	209	210	212	217	224	233	245	259	275	294	—	—	—	—
	Low Speed (Tap 2)	CFM	1360 [642]	1240 [585]	1120 [529]	1020 [481]	930 [439]	840 [396]	770 [363]	720 [340]	—	—	—	—	—	—	—	—	—
	Watts	158	147	140	136	137	141	150	163	—	—	—	—	—	—	—	—	—	—
	High Speed (Tap 1)	CFM	1510 [713]	1440 [680]	1380 [651]	1320 [623]	1270 [599]	1220 [576]	1170 [552]	1120 [529]	1080 [510]	1050 [496]	—	—	—	—	—	—	—
	Watts	222	226	231	239	247	258	270	284	299	316	—	—	—	—	—	—	—	—
TZHH6-A042J	2 X13 (ECM Motor)	1225	1575	230	Low Speed (Tap 2)	CFM	1360 [642]	1240 [585]	1130 [533]	1030 [486]	940 [444]	860 [406]	790 [373]	730 [345]	—	—	—	—	
					Watts	158	147	140	136	137	141	150	163	—	—	—	—	—	—
	High Speed (Tap 1)	CFM	1510 [713]	1450 [684]	1390 [656]	1330 [628]	1280 [604]	1240 [585]	1190 [562]	1150 [543]	1110 [524]	1080 [510]	—	—	—	—	—	—	—
	Watts	210	221	232	244	256	269	282	295	309	323	—	—	—	—	—	—	—	—
	Low Speed (Tap 2)	CFM	1440 [680]	1390 [656]	1330 [628]	1280 [604]	1230 [581]	1190 [562]	1140 [538]	1100 [519]	1060 [500]	1020 [481]	—	—	—	—	—	—	—
	Watts	209	224	239	253	267	280	293	306	319	332	—	—	—	—	—	—	—	—
TZHH6-A042J	2 X13 (ECM Motor)	1225	1575	230	High Speed (Tap 1)	CFM	1640 [774]	1600 [755]	1550 [732]	1510 [713]	1470 [694]	1420 [670]	1380 [651]	1340 [632]	1300 [614]	1250 [590]	—	—	—
					Watts	286	307	327	346	365	382	399	415	430	444	—	—	—	—
	Low Speed (Tap 2)	CFM	1440 [680]	1390 [656]	1340 [632]	1280 [604]	1240 [585]	1190 [562]	1140 [538]	1100 [519]	1060 [500]	1020 [481]	—	—	—	—	—	—	—
	Watts	215	229	243	257	272	286	301	315	330	345	—	—	—	—	—	—	—	—
	High Speed (Tap 1)	CFM	1640 [774]	1600 [755]	1560 [736]	1520 [717]	1480 [699]	1430 [675]	1390 [656]	1350 [637]	1310 [618]	1260 [595]	—	—	—	—	—	—	—
	Watts	295	312	329	347	366	384	404	423	443	463	—	—	—	—	—	—	—	—

[ ] Designates Metric Conversions

# INDOOR AIRFLOW PERFORMANCE — 208/240 VOLTS

Model	Motor Speed from Factory	Recommended Airflow Range		Voltage	Motor Speed (Tap Setting)	External Static Pressure—Inches W.C. [kPa]										
		Min	Max			0.1 [0.02]	0.2 [0.05]	0.3 [0.07]	0.4 [0.10]	0.5 [0.12]	0.6 [0.15]	0.7 [0.17]	0.8 [0.20]	0.9 [0.22]	1.0 [0.25]	
TZHH6-A048J	2 X13 (ECM Motor)	1400	1800	208	Low Speed (Tap 2)	CFM 1600 [755]	1550 [732]	1510 [713]	1460 [689]	1420 [670]	1380 [651]	1340 [632]	1300 [614]	1260 [595]	1230 [581]	
					Watts	226	241	257	273	289	305	321	338	355	372	
					High Speed (Tap 1)	CFM 1840 [868]	1810 [854]	1770 [835]	1740 [821]	1700 [802]	1660 [784]	1620 [765]	1570 [741]	1530 [722]	1480 [699]	
					Watts	348	365	382	400	419	439	460	481	504	527	
					Low Speed (Tap 2)	CFM 1600 [755]	1550 [732]	1510 [713]	1470 [694]	1430 [675]	1390 [656]	1350 [637]	1310 [618]	1270 [599]	1240 [585]	
	Watts	226	241	257	273	289	305	321	338	355	372					
	High Speed (Tap 1)	CFM 1840 [868]	1810 [854]	1780 [840]	1740 [821]	1710 [807]	1670 [788]	1630 [769]	1590 [750]	1550 [732]	1510 [713]					
	Watts	361	377	393	411	430	451	472	495	519	545					
	TZHH6-A060J	1 X13 (ECM Motor)	1225	1575	208	1st Stage Low Speed (Tap 1)	CFM 1430 [675]	1370 [647]	1310 [618]	1260 [595]	1200 [566]	1150 [543]	1100 [519]	1060 [500]	1020 [481]	980 [463]
						Watts	200	213	225	238	251	263	276	289	302	315
1st Stage High Speed (Tap 2)						CFM 1560 [736]	1510 [713]	1470 [694]	1420 [670]	1380 [651]	1340 [632]	1290 [609]	1250 [590]	1210 [571]	1170 [552]	
Watts						253	269	284	300	315	330	345	359	374	388	
2nd Stage Low Speed (Tap 3)						CFM 1710 [807]	1670 [788]	1620 [765]	1580 [746]	1530 [722]	1490 [703]	1450 [684]	1400 [661]	1360 [642]	1320 [623]	
Watts		322	338	354	370	386	403	419	436	453	470					
2nd Stage Med. Speed (Tap 4)		CFM 1900 [897]	1870 [883]	1830 [864]	1790 [845]	1750 [826]	1710 [807]	1670 [788]	1620 [765]	1580 [746]	1530 [722]					
Watts		446	461	477	492	509	525	543	560	578	597					
2nd Stage High Speed (Tap 5)		CFM 2100 [991]	2060 [972]	2030 [958]	1990 [939]	1950 [920]	1910 [902]	1870 [883]	1840 [868]	1800 [850]	1760 [831]					
Watts		594	610	626	643	659	676	692	709	725	742					
TZHH6-A060J	1 X13 (ECM Motor)	1225	1575	230	1st Stage Low Speed (Tap 1)	CFM 1430 [675]	1370 [647]	1310 [618]	1260 [595]	1200 [566]	1160 [548]	1110 [524]	1060 [500]	1020 [481]	990 [467]	
					Watts	207	219	231	243	255	268	280	293	305	318	
					1st Stage High Speed (Tap 2)	CFM 1560 [736]	1520 [717]	1470 [694]	1430 [675]	1380 [651]	1340 [632]	1300 [614]	1260 [595]	1220 [576]	1180 [557]	
					Watts	255	272	288	305	320	335	349	363	377	390	
					2nd Stage Low Speed (Tap 3)	CFM 1720 [812]	1670 [788]	1630 [769]	1590 [750]	1550 [732]	1500 [708]	1460 [689]	1420 [670]	1380 [651]	1340 [632]	
	Watts	328	342	357	373	389	406	424	442	461	480					
	2nd Stage Med. Speed (Tap 4)	CFM 1910 [902]	1870 [883]	1840 [868]	1800 [850]	1760 [831]	1720 [812]	1680 [793]	1640 [774]	1590 [750]	1550 [732]					
	Watts	452	468	484	501	518	535	553	572	590	610					
	2nd Stage High Speed (Tap 5)	CFM 2120 [1001]	2080 [982]	2050 [968]	2010 [949]	1980 [935]	1940 [916]	1900 [897]	1860 [878]	1820 [859]	1780 [840]					
	Watts	599	618	636	655	674	692	711	730	748	767					

[ ] Designates Metric Conversions

ELECTRICAL DATA – TZHH4 SERIES									
		-A024JK	-A030JK	-A036CK	-A036JK	-A037CK	-A037JK	-A042CK	-A042JK
Unit Information	Unit Operating Voltage Range	187-253	187-253	187-253	187-253	187-253	187-253	187-253	187-253
	Minimum Circuit Ampacity	23/23	21/21	19/19	27/27	19/19	27/27	26/26	36/36
	Minimum Overcurrent Protection Device Size	30/30	30/30	25/25	35/35	25/25	35/35	30/30	45/45
	Maximum Overcurrent Protection Device Size	35/35	35/35	25/25	40/40	25/25	40/40	35/35	50/50
Compressor Motor	No.	1	1	1	1	1	1	1	1
	Volts	208/230	208/230	208/230	208/230	208/230	208/230	208/230	208/230
	Phase	1	1	3	1	3	1	3	1
	HP	2	2.5	3	3	3	3	3.5	3.5
	RPM	3450	3450	3450	3450	3450	3450	3450	3450
	Amps (RLA)	13.5/13.5	14.1/14.1	10.4/10.4	16.7/16.7	10.4/10.4	16.7/16.7	14.1/14.1	21.8/21.8
	Amps (LRA)	58.3/58.3	73/73	88/88	79/79	88/88	79/79	95/95	112/112
Condenser Motor	No.	1	1	1	1	1	1	1	1
	Volts	208/230	208/230	208/230	208/230	208/230	208/230	208/230	208/230
	Phase	1	1	1	1	1	1	1	1
	HP	1/3	1/3	1/3	1/3	1/3	1/3	1/3	1/3
	Amps (FLA)	1.5	1.5	1.5	1.5	1.5/1.5	1.5/1.5	1.9	1.9
	Amps (LRA)	3	3	3	3	3/3	3/3	4	4
Evaporator Fan	No.	1	1	1	1	1	1	1	1
	Volts	208/230	208/230	208/230	208/230	208/230	208/230	208/230	208/230
	Phase	1	1	1	1	1	1	1	1
	HP	1/2	1/2	1/2	1/2	1/2	1/2	3/4	3/4
	Amps (FLA)	4.1	4.1	4.1	4.1	4.1/4.1	4.1/4.1	6	6

ELECTRICAL DATA – TZHH4 SERIES									
		-A043CK	-A043JK	-A048CK	-A048JK	-A049CK	-A049JK	-A060CK	-A060JK
Unit Information	Unit Operating Voltage Range	187-253	187-253	187-253	187-253	187-253	187-253	187-253	187-253
	Minimum Circuit Ampacity	25/25	31/31	26/26	36/36	26/26	36/36	32/32	43/43
	Minimum Overcurrent Protection Device Size	25/25	35/35	30/30	45/45	30/30	45/45	40/40	50/50
	Maximum Overcurrent Protection Device Size	35/35	45/45	35/35	50/50	35/35	50/50	45/45	60/60
Compressor Motor	No.	1	1	1	1	1	1	1	1
	Volts	208/230	208/230	208/230	208/230	208/230	208/230	208/230	208/230
	Phase	3	1	3	1	3	1	3	1
	HP	3450	3450	4	4	3450	3450	4.5	4.5
	RPM	3 1/2	3 1/2	3450	3450	4	4	3450	3450
	Amps (RLA)	13.5/13.5	17.9/17.9	13.7/13.7	21.8/21.8	13.7/13.7	21.8/21.8	17.9/17.9	26.4/26.4
	Amps (LRA)	88/88	112/112	110/110	117/117	110/110	117/117	120/120	150/150
Condenser Motor	No.	1	1	1	1	1	1	1	1
	Volts	208/230	208/230	208/230	208/230	208/230	208/230	208/230	208/230
	Phase	1	1	1	1	1	1	1	1
	HP	1/3	1/3	1/3	1/3	1/3	1/3	1/3	1/3
	Amps (FLA)	1.9/1.9	1.9/1.9	1.9	1.9	1.9/1.9	1.9/1.9	1.9	1.9
	Amps (LRA)	4/4	4/4	4	4	4/4	4/4	4	4
Evaporator Fan	No.	1	1	1	1	1	1	1	1
	Volts	208/230	208/230	208/230	208/230	208/230	208/230	208/230	208/230
	Phase	1	1	1	1	1	1	1	1
	HP	3/4	3/4	3/4	3/4	3/4	3/4	1	1
	Amps (FLA)	6/6	6/6	6	6	6/6	6/6	7.6	7.6

ELECTRICAL DATA – TZHH6 SERIES							
		-A024JK	-A030JK	-A036JK	-A042JK	-A048JK	-A060JK
Unit Information	Unit Operating Voltage Range	187-253	187-253	187-253	187-253	187-253	197-253
	Volts	208/230	208/230	208/230	208/230	208/230	208/230
	Minimum Circuit Ampacity	23/23	22/22	24/24	31/31	33/33	46/46
	Minimum Overcurrent Protection Device Size	30/30	25/25	30/30	35/35	40/40	60/60
	Maximum Overcurrent Protection Device Size	35/35	30/30	35/35	45/45	50/50	60/60
Compressor Motor	No.	1	1	1	1	1	1
	Volts	208/230	208/230	208/230	208/230	208/230	208/230
	Phase	1	1	1	1	1	1
	RPM	3450	3450	3450	3450	3450	3450
	HP, Compressor 1	2	2 1/2	3	3 1/2	4	5
	Amps (RLA), Comp. 1	13.5/13.5	12.8/12.8	14.1/14.1	17.9/17.9	19.9/19.9	28.8/28.8
	Amps (LRA), Comp. 1	58.3/58.3	64/64	77/77	112/112	109/109	152.9/152.9
Condenser Motor	No.	1	1	1	1	1	1
	Volts	208/230	208/230	208/230	208/230	208/230	208/230
	Phase	1	1	1	1	1	1
	HP	1/3	1/3	1/3	1/3	1/3	1/3
	Amps (FLA, each)	1.5/1.5	1.5/1.5	1.5/1.5	1.9/1.9	1.9/1.9	1.9/1.9
	Amps (LRA, each)	3/3	3/3	3/3	4/4	4/4	4/4
Evaporator Fan	No.	1	1	1	1	1	1
	Volts	208/230	208/230	208/230	208/230	208/230	208/230
	Phase	1	1	1	1	1	1
	HP	1/2	1/2	1/2	3/4	3/4	1
	Amps (FLA, each)	4.1/4.1	4.1/4.1	4.1/4.1	6/6	6/6	7.6/7.6
	Amps (LRA, each)	0/0	0/0	0/0	0/0	0/0	0/0

**208-240 VOLT, SINGLE PHASE, 60 HZ, AUXILIARY ELECTRIC HEATER KITS CHARACTERISTICS AND APPLICATION**

Separate Power Supply For Both Unit and Heater Kit														
Unit Model No. TZHH4	Single Power Supply For Both Unit and Heater Kit							Separate Power Supply For Both Unit and Heater Kit						
	Heater Kit				Heat Pump			Heater Kit				Heat Pump		
	RXQJ-Heater Kit Nominal kW	No. of Elements	No. of Sequence Steps	Rated Heater kW @ 208-240 V	Heater KBTU/Hr @ 208-240 V	Heater Amp. @ 208-240 V	Unit Min. Ckt. Ampacity @ 208-240 V	Over Current Protective Device Size Min./Max. @ 208 V	Over Current Protective Device Size Min./Max. @ 240 V	Min. Circuit Ampacity 208-240 V	Max. Fuse Size	Min. Ckt. Ampacity	Over Current Protective Device Size Min./Max. @ 208 V	Over Current Protective Device Size Min./Max. @ 240 V
A024J	No Heat	—	—	—	—	—	23/23	30/35	30/35	23/23	—	—	30/35	30/35
	C05J	1	1	3.6/4.8	12.28/16.38	17.33/20	45/48	45/50	50/50	22/25	25/25	—	—	—
	C07J	1	1	5.4/7.2	18.42/24.56	26/30	55/60	60/60	60/60	33/38	35/40	—	—	—
A030J	C10J	2	1	7.2/9.6	24.57/32.76	34.7/40	66/73	70/70	80/80	44/50	45/50	—	—	—
	No Heat	—	—	—	—	—	24/24	30/35	30/35	—	—	24/24	30/35	30/35
	C05J	1	1	3.6/4.8	12.28/16.38	17.33/20	45/49	45/50	50/50	22/25	25/25	—	—	—
A036J A037J	C07J	1	1	5.4/7.2	18.42/24.56	26/30	56/61	60/60	70/70	33/38	35/40	—	—	—
	C10J	2	1	7.2/9.6	24.57/32.76	34.7/40	67/74	70/70	80/80	44/50	45/50	—	—	—
	C15J	3	2	10.8/14.4	36.85/49.13	52/60	89/99	90/90	100/100	65/75	70/80	—	—	—
A042J	C20J	4	2	14.4/19.2	49.12/65.52	69.33/80	114/127	125/125	150/150	87/100	90/100	—	—	—
	No Heat	—	—	—	—	—	27/27	35/40	35/40	—	—	27/27	35/40	35/40
	C05J	1	1	3.6/4.8	12.28/16.38	17.33/20	49/52	50/60	60/60	22/25	25/25	—	—	—
A043J	C07J	1	1	5.4/7.2	18.42/24.56	26/30	59/64	60/60	70/70	33/38	35/40	—	—	—
	C10J	2	1	7.2/9.6	24.57/32.76	34.7/40	70/77	70/70	80/80	44/50	45/50	—	—	—
	C15J	3	2	10.8/14.4	36.85/49.13	52/60	92/102	100/100	110/110	65/75	70/80	—	—	—
A048J A049J	C20J	4	2	14.4/19.2	49.12/65.52	69.33/80	114/136	125/125	150/150	87/100	90/100	—	—	—
	No Heat	—	—	—	—	—	36/36	45/50	45/50	—	—	36/36	45/50	45/50
	C05J	1	1	3.6/4.8	12.28/16.38	17.33/20	53/56	60/60	60/60	22/25	25/25	—	—	—
A060J	C07J	1	1	5.4/7.2	18.42/24.56	26/30	65/69	70/70	70/70	33/38	35/40	—	—	—
	C10J	2	1	7.2/9.6	24.57/32.76	34.7/40	75/81	80/80	90/90	44/50	45/50	—	—	—
	C15J	3	2	10.8/14.4	36.85/49.13	52/60	96/106	100/100	110/110	65/75	70/80	—	—	—
A066J	C20J	4	2	14.4/19.2	49.12/65.52	69.33/80	118/131	125/125	150/150	87/100	90/100	—	—	—
	No Heat	—	—	—	—	—	36/36	45/50	45/50	—	—	36/36	45/50	45/50
	C05J	1	1	3.6/4.8	12.28/16.38	17.33/20	57/61	60/70	70/70	22/25	25/25	—	—	—
A060J	C07J	1	1	5.4/7.2	18.42/24.56	26/30	68/73	70/80	80/80	33/38	35/40	—	—	—
	C10J	2	1	7.2/9.6	24.57/32.76	34.7/40	79/86	80/90	90/90	44/50	45/50	—	—	—
	C15J	3	2	10.8/14.4	36.85/49.13	52/60	101/111	110/110	125/125	65/75	70/80	—	—	—
A060J	C20J	4	2	14.4/19.2	49.12/65.52	69.33/80	122/136	125/125	150/150	87/100	90/100	—	—	—
	No Heat	—	—	—	—	—	43/43	50/60	50/60	—	—	43/43	50/60	50/60
	C05J	1	1	3.6/4.8	12.28/16.38	17.33/20	65/68	80/80	80/80	22/25	25/25	—	—	—
A060J	C07J	1	1	5.4/7.2	18.42/24.56	26/30	75/80	90/90	90/90	33/38	35/40	—	—	—
	C10J	2	1	7.2/9.6	24.57/32.76	34.7/40	86/93	90/100	100/100	44/50	45/50	—	—	—
	C15J	3	2	10.8/14.4	36.85/49.13	52/60	108/118	110/110	125/125	65/75	70/80	—	—	—
A060J	C20J	4	2	14.4/19.2	49.12/65.52	69.33/80	130/143	150/150	150/150	87/100	90/100	—	—	—

**208-240 VOLT, THREE PHASE, 60 HZ, AUXILIARY ELECTRIC HEATER KITS CHARACTERISTICS AND APPLICATION**

Separate Power Supply For Both Unit and Heater Kit												
Unit Model No. TZHH4	Single Power Supply For Both Unit and Heater Kit						Separate Power Supply For Both Unit and Heater Kit					
	Heater Kit			Heat Pump			Heater Kit			Heat Pump		
	RXQJ-Heater Kit Nominal kW	No. of Elements	No. of Sequence Steps	Rated Heater kW @ 208-240 V	Heater KBTU/Hr @ 208-240 V	Heater Amp. @ 208-240 V	Unit Min. Ckt. Ampacity @ 208-240 V	Over Current Protective Device Size Min./Max. @ 208 V	Min. Ckt. Ampacity	Max. Fuse Size	Min. Circuit Ampacity 208-240 V	Over Current Protective Device Size Min./Max. @ 240 V
A036C A037C	No Heat	—	—	—	—	—	19/19	25/25	—	—	19/19	25/25
	C10C	2	1	7.2/9.6	24.57/32.76	20/23.1	44/48	45/45	25/30	—	—	—
	C15C	3	2	10.8/14.4	36.85/49.13	30.1/34.7	57/61	60/60	40/45	—	—	—
A042C	No Heat	—	—	—	—	—	26/26	30/35	—	—	26/26	30/35
	C10C	2	1	7.2/9.6	24.57/32.76	20/23.1	51/55	60/60	25/30	—	—	—
	C15C	3	2	10.8/14.4	36.85/49.13	30.1/34.7	64/69	70/70	40/45	—	—	—
	C20C	4	2	14.4/19.2	49.12/65.52	40/46.3	76/84	80/80	50/60	—	—	—
A043C	No Heat	—	—	—	—	—	25/25	35/35	—	—	25/25	30/35
	C10C	2	1	7.2/9.6	24.57/32.76	20/23.1	50/54	50/50	25/30	—	—	—
	C15C	3	2	10.8/14.4	36.85/49.13	30.1/34.7	63/69	70/70	40/45	—	—	—
	C20C	4	2	14.4/19.2	49.12/65.52	40/46.3	75/83	80/80	50/60	—	—	—
A048C A049C	No Heat	—	—	—	—	—	26/26	30/35	—	—	26/26	30/35
	C10C	2	1	7.2/9.6	24.57/32.76	20/23.1	51/54	60/60	25/30	—	—	—
	C15C	3	2	10.8/14.4	36.85/49.13	30.1/34.7	63/69	70/70	40/45	—	—	—
	C20C	4	2	14.4/19.2	49.12/65.52	40/46.3	76/83	80/80	50/60	—	—	—
A060C	No Heat	—	—	—	—	—	32/32	40/45	—	—	32/32	40/45
	C10C	2	1	7.2/9.6	24.57/32.76	20/23.1	57/61	60/60	25/30	—	—	—
	C15C	3	2	10.8/14.4	36.85/49.13	30.1/34.7	69/76	70/70	40/45	—	—	—
	C20C	4	2	14.4/19.2	49.12/65.52	40/46.3	82/90	90/90	50/60	—	—	—



**208-240 VOLT, SINGLE PHASE, 60 HZ, AUXILIARY ELECTRIC HEATER KITS CHARACTERISTICS AND APPLICATION**

Unit Model No. TZHH6	Heater Kit Model No. RXQJ-	Heater kW @ 208/240 V	Heater Kit FLA	Unit Min. Ckt. Ampacity	Max. Fuse or Ckt. Bkr. Size (Ckt. Bkr. Must be HACR Type for USA)	Heater Kit Min. Ckt. Ampacity	Heater Kit Max. Fuse (Ckt. Bkr. Must be HACR Type for USA)	Heat Pump Min. Ckt. Ampacity	Heat Pump Max. Fuse or Ckt. Bkr. Size (Ckt. Bkr. Must be HACR Type for USA)
A024JK	NONE	—	—	23/23	35/35	—	—	23/23	35/35
	C05J	3.6/4.8	17.3/20	45/48	50/50	22/25	25/25	23/23	35/35
	C07J	5.4/7.2	26/30	56/61	60/70	33/38	35/40	23/23	35/35
	C10J	7.2/9.6	34.7/40	67/73	70/80	44/50	45/50	23/23	35/35
A030JK	C15J	10.8/14.4	52/60	88/98	90/100	65/75	70/80	23/23	35/35
	NONE	—	—	22/22	30/30	—	—	22/22	30/30
	C05J	3.6/4.8	17.3/20	44/47	50/50	22/25	25/25	22/22	30/30
	C07J	5.4/7.2	26/30	55/60	60/70	33/38	35/40	22/22	30/30
A036JK	C10J	7.2/9.6	34.7/40	66/72	70/80	44/50	45/50	22/22	30/30
	C15J	10.8/14.4	52/60	87/97	90/100	65/75	70/80	22/22	30/30
	NONE	—	—	24/24	35/35	—	—	24/24	35/35
	C05J	3.6/4.8	17.3/20	46/49	50/50	22/25	25/25	24/24	35/35
A042JK	C07J	5.4/7.2	26/30	57/62	60/70	33/38	35/40	24/24	35/35
	C10J	7.2/9.6	34.7/40	68/74	70/80	44/50	45/50	24/24	35/35
	C15J	10.8/14.4	52/60	89/99	90/100	65/75	70/80	24/24	35/35
	C20J	14.4/19.2	69.3/80	118/131	125/150	87/100	90/100	24/24	35/35
A048JK	NONE	—	—	31/31	45/45	—	—	31/31	45/45
	C05J	3.6/4.8	17.3/20	53/56	60/60	22/25	25/25	31/31	45/45
	C07J	5.4/7.2	26/30	64/69	70/70	33/38	35/40	31/31	45/45
	C10J	7.2/9.6	34.7/40	75/81	80/90	44/50	45/50	31/31	45/45
A060JK	C15J	10.8/14.4	52/60	96/106	100/110	65/75	70/80	31/31	45/45
	C20J	14.4/19.2	69.3/80	120/133	125/150	87/100	90/100	31/31	45/45
	NONE	—	—	33/33	50/50	—	—	33/33	50/50
	C05J	3.6/4.8	17.3/20	55/58	60/70	22/25	25/25	33/33	50/50
A060JK	C07J	5.4/7.2	26/30	66/71	70/80	33/38	35/40	33/33	50/50
	C10J	7.2/9.6	34.7/40	77/83	80/90	44/50	45/50	33/33	50/50
	C15J	10.8/14.4	52/60	98/108	100/110	65/75	70/80	33/33	50/50
	C20J	14.4/19.2	69.3/80	120/133	125/150	87/100	90/100	33/33	50/50
A060JK	NONE	—	—	46/46	60/60	—	—	46/46	60/60
	C05J	3.6/4.8	17.3/20	68/71	90/90	22/25	25/25	46/46	60/60
	C07J	5.4/7.2	26/30	79/84	100/100	33/38	35/40	46/46	60/60
	C10J	7.2/9.6	34.7/40	90/96	100/110	44/50	45/50	46/46	60/60
A060JK	C15J	10.8/14.4	52/60	111/121	125/125	65/75	70/80	46/46	60/60
	C20J	14.4/19.2	69.3/80	133/146	150/150	87/100	90/100	46/46	60/60

## DIMENSIONS

Model	Height "A"
TZHH4: 024, 030, 036 TZHH6: 024	29 1/8"
TZHH4: 042, 048, 060 TZHH6: 030, 036, 042, 048, 060	37 1/8"

## FRONT VIEW

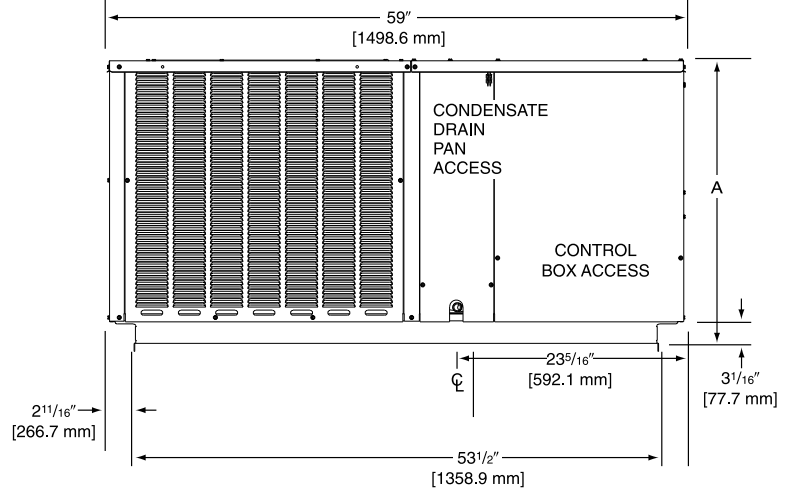

## REAR VIEW

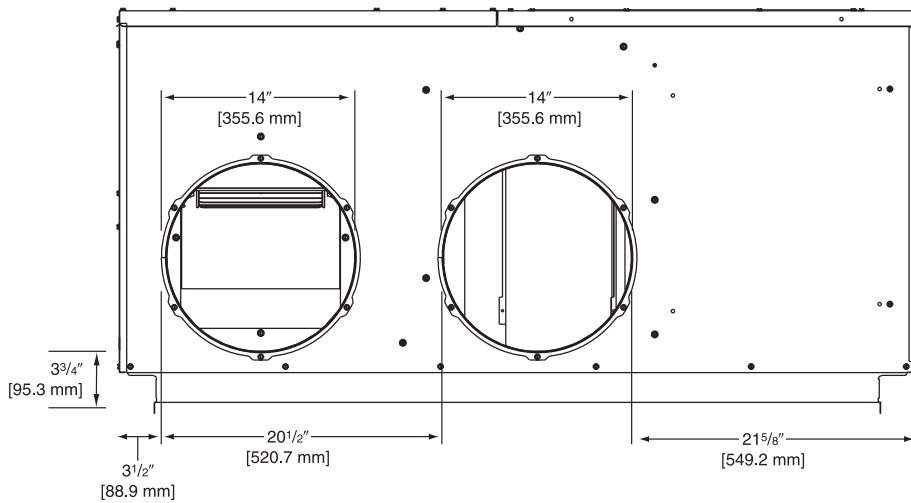

## ELECTRICAL CONNECTIONS

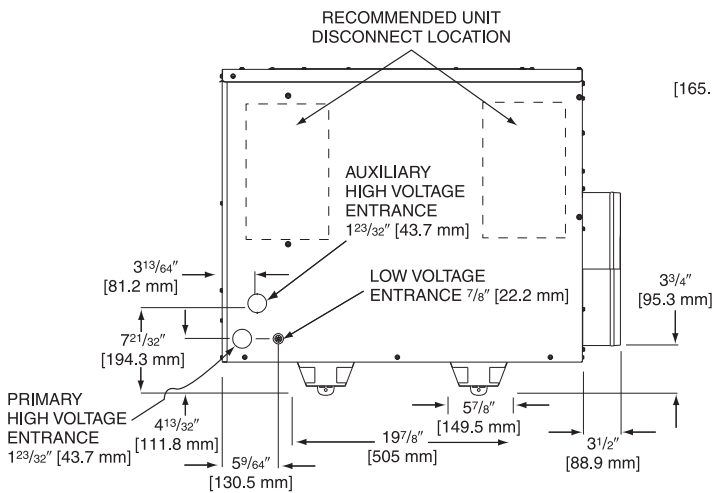

## BOTTOM VIEW

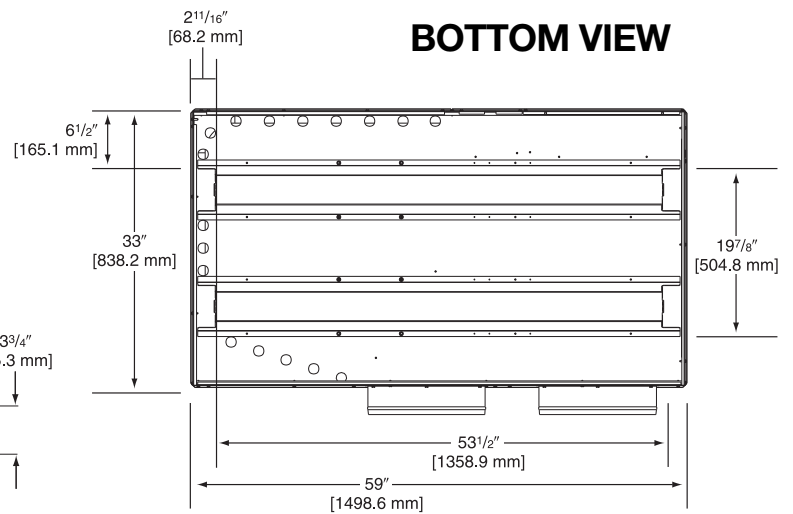

[ ] Designates Metric Conversions

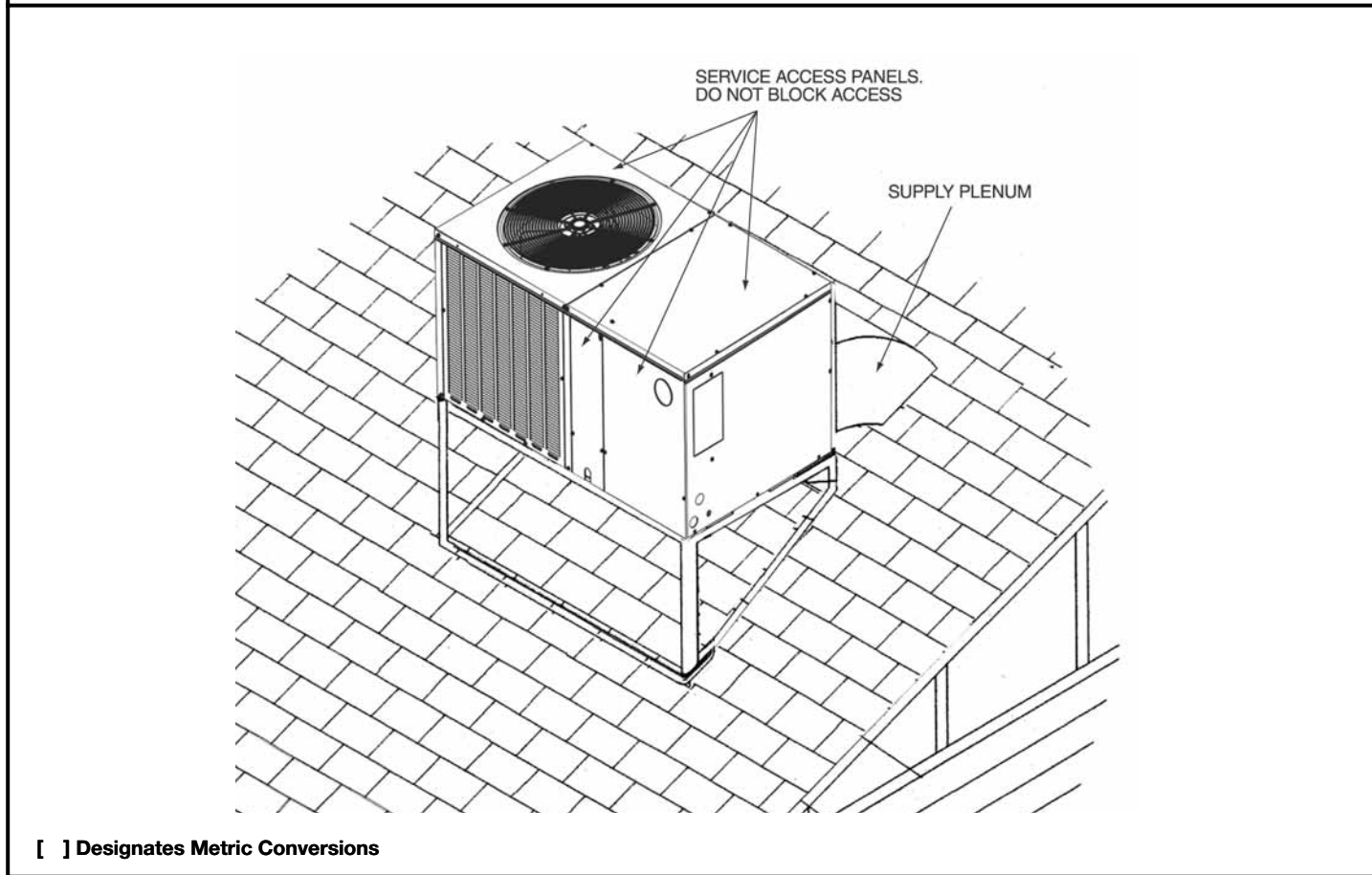
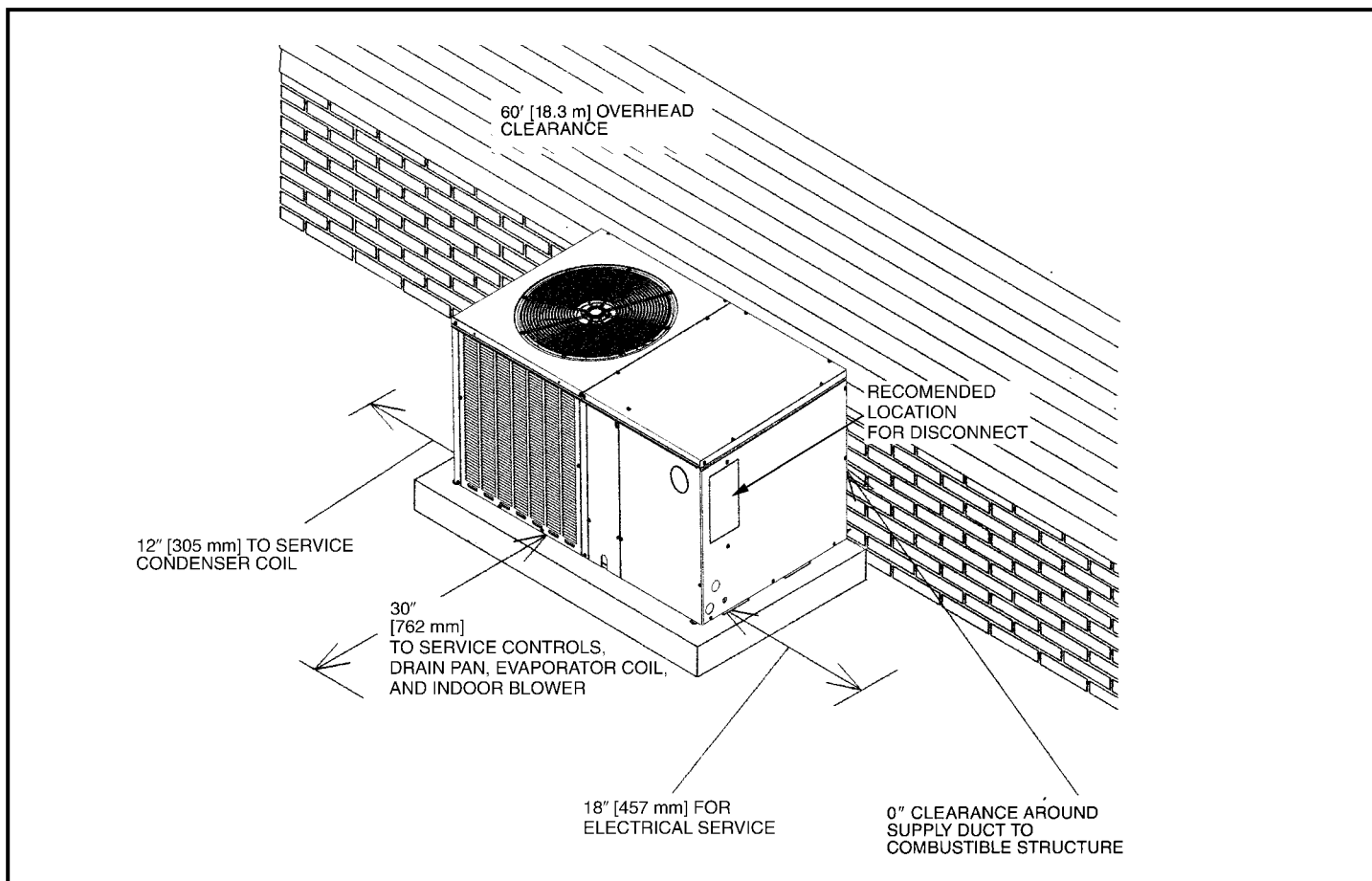

[ ] Designates Metric Conversions

**BEFORE PURCHASING THIS APPLIANCE, READ IMPORTANT ENERGY COST AND EFFICIENCY INFORMATION AVAILABLE FROM YOUR RETAILER.**

**GENERAL TERMS OF LIMITED WARRANTY\***

Thermal Zone will furnish a replacement for any part of this product which fails in normal use and service within the applicable periods stated, in accordance with the terms of the limited warranty.

**\*For complete details of the Limited and Conditional Warranties, including applicable terms and conditions, contact your local contractor or the Manufacturer for a copy of the product warranty certificate.**

**Conditional Parts (Registration Required)**

1 Phase, Residential Applications .....Ten (10) Years

**Compressor**

1 Phase, Residential Applications.....Ten (10) Years

1 & 3 Phase, Commercial Applications .....Five (5) Years

**Parts**

1 & 3 Phase, Commercial Applications .....One (1) Year







---

**Before proceeding with installation, refer to installation instructions packaged with each model, as well as complying with all Federal, State, Provincial, and Local codes, regulations, and practices.**

*"In keeping with its policy of continuous progress and product improvement, the right is reserved to make changes without notice."*