



## AIR CONDITIONERS



### TZALS-16 SERIES

Efficiencies up to 16 SEER/13 EER  
 Nominal Sizes 1 1/2 to 5 Ton [5.28 to 17.6 kW]  
 Cooling Capacities 17.3 to 60.5 kBTU  
 [5.7 to 17.7 kW]

#### Features

- New composite base pan – dampens sound, captures louver panels, eliminates corrosion and reduces number of fasteners needed
- Powder coat paint system – for a long lasting professional finish
- Scroll compressor – uses 70% fewer moving parts for higher efficiency and increased reliability
- Modern cabinet aesthetics – increased curb appeal with visually appealing design
- Louver panels – provide ultimate coil protection, enhance cabinet strength, and increased cabinet rigidity
- Optimized fan orifice – optimizes airflow and reduces unit sound
- Rust resistant screws – confirmed through 1500-hour salt spray testing
- 3"-4"-5" service valve space – provides a minimum working area of 27-square inches for easier access
- 15" wide, industry leading corner service access – makes repairs easier and faster
- External gauge port access – allows easy connection of "low-loss" gauge ports
- Single-row condenser coil – makes unit lighter and allows thorough coil cleaning to maintain "out of the box" performance
- Fewer cabinet fasteners and fastener-free base – allow for faster access to internal components and hassle-free panel removal
- Service trays – hold fasteners or caps during service calls
- QR code – provides technical information on demand for faster service calls
- Fan motor harness with extra long wires allows unit top to be removed without disconnecting fan wire.

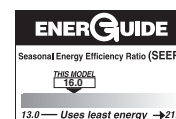

## TABLE OF CONTENTS

Model Number Identification .....	3
Available SKUs .....	3
General Data/Electrical Data .....	4
Accessories .....	5
Weighted Sound Power .....	5
Unit Dimensions.....	6
Clearances.....	7
Wiring Diagrams .....	8
Application Guidelines .....	8
Refrigerant Line Size Information .....	9-10
Performance Data .....	11
Guide Specifications .....	12
Limited Warranty .....	13

## Model Number Identification

<u>TZ</u>	<u>A</u>	<u>L</u>	<u>S</u>	<u>16</u>	<u>18</u>	<u>2</u>	<u>A</u>	<u>A</u>
Brand	Product	Refrigerant	Motor	SEER	Capacity	Voltage	Region	Minor Series
Thermal Zone	A = Air Conditioner	L = R410A	S = Single Stage D = Dual Stage	16 = 16 SEER	18 - 18,000 [5.28 kW] 24 - 24,000 [7.03 kW] 30 - 30,000 [8.79 kW] 36 - 36,000 [10.55 kW] 42 - 42,000 [12.31 kW] 48 - 48,000 [14.07 kW] 60 - 60,000 [17.58 kW]	2 = 1 ph 208-230/60 C = 3 ph 208/230/60 D = 3 ph 460/60	A = All Regions	A = First Design Series P = First Design Series with HPC/LPC

[ ] Designates Metric Conversions

## Available SKUs

Available Models
TZALS16182AA
TZALS16182AP
TZALS16242AA
TZALS16242AP
TZALS16302AA
TZALS16302AP
TZALS16362AA
TZALS16362AP
TZALS1636CAP
TZALS16422AA
TZALS16422AP
TZALS1642CAP
TZALS16482AA
TZALS16482AP
TZALS1648CAP
TZALS16602AA
TZALS16602AP
TZALS1660CAP

<b>Physical Data</b>							
<b>PHYSICAL DATA</b>							
<b>Model No.</b>	<b>TZALS1618</b>	<b>TZALS1624</b>	<b>TZALS1630</b>	<b>TZALS1636</b>	<b>TZALS1642</b>	<b>TZALS1648</b>	<b>TZALS1660</b>
<b>Nominal Tonnage</b>	1.5	2.0	2.5	3.0	3.5	4.0	5.0
<b>Valve Connections</b>							
Liquid Line O.D. – in.	3/8	3/8	3/8	3/8	3/8	3/8	3/8
Suction Line O.D. – in.	3/4	3/4	3/4	3/4	7/8	7/8	7/8
<b>Refrigerant (R410A) furnished oz.<sup>1</sup></b>	82	87	113	108	150	174	201
<b>Compressor Type</b>	Scroll						
<b>Outdoor Coil</b>							
Net face area – Outer Coil	12.1	14.8	16.2	18.8	24.2	28.3	32.3
Net face area – Inner Coil	-	-	-	-	-	-	-
Tube diameter – in.	0.375	0.375	0.375	0.375	0.375	0.375	0.375
Number of rows	1	1	1	1	1	1	1
Fins per inch	22	22	22	22	22	22	22
<b>Outdoor Fan</b>							
Diameter – in.	20	24	26	26	26	26	26
Number of blades	3	2	3	3	3	3	3
Motor hp	1/8	1/6	1/3	1/3	1/3	1/3	1/3
CFM	2405	2851	3915	4340	4450	4660	4775
RPM	1095	851	710	819	829	789	795
watts	156	147	103	131	193	198	239
<b>Shipping weight – lbs.</b>	155	170	195	204	253	268	296
<b>Operating weight – lbs.</b>	148	163	188	197	246	261	289
<b>Electrical Data</b>							
<b>Line Voltage Data (Volts-Phase-Hz)</b>	<b>208/230-1-60</b>	<b>208/230-1-60</b>	<b>208/230-1-60</b>	<b>208/230-1-60</b>	<b>208/230-1-60</b>	<b>208/230-1-60</b>	<b>208/230-1-60</b>
<b>Maximum overcurrent protection (amps)<sup>2</sup></b>	20	20	30	35	40	40	50
<b>Minimum circuit ampacity<sup>3</sup></b>	12	14	19	23	25	25	34
<b>Compressor</b>							
Rated load amps	9	10.3	12.8	15.4	16.7	17	23.7
Locked rotor amps	47.5	61.6	67.3	83.9	109	123.9	152.5
<b>Condenser Fan Motor</b>							
Full load amps	0.7	0.6	2.8	3.5	3.5	3.5	3.5
Locked rotor amps	1.3	1.5	2.3	1.5		2.3	
<b>Line Voltage Data (Volts-Phase-Hz)</b>				<b>208/230-3-60</b>	<b>208/230-3-60</b>	<b>208/230-3-60</b>	<b>208/230-3-60</b>
<b>Maximum overcurrent protection (amps)<sup>2</sup></b>				25	25	30	35
<b>Minimum circuit ampacity<sup>3</sup></b>				17	18	21	24
<b>Compressor</b>							
Rated load amps				10.4	11.2	13.6	15.9
Locked rotor amps				73	88	83.1	110
<b>Condenser Fan Motor</b>							
Full load amps				3.5	3.5	3.5	3.5
Locked rotor amps						2.3	

<sup>1</sup>Refrigerant charge sufficient for 15 ft. length of refrigerant lines. For longer line set requirements see the installation instructions for information about set length and additional refrigerant charge required.

<sup>2</sup>HACR type circuit breaker or fuse.

<sup>3</sup>Refer to National Electrical Code manual to determine wire, fuse and disconnect size requirements.

## Accessories

Model No.	TZALS1618	TZALS1624	TZALS1630	TZALS1636	TZALS1642	TZALS1648	TZALS1660	
Compressor crankcase heater*	44-17402-44	44-17402-44	44-17402-44	44-17402-44	44-17402-45	44-17402-45	44-17402-45	
Low ambient control	RXAD-A08	RXAD-A08	RXAD-A08	RXAD-A08	RXAD-A08	RXAD-A08	RXAD-A08	
Freeze Stat	50313	50313	50313	50313	50313	50313	50313	
Compressor sound cover	68-23427-26	68-23427-26	68-23427-26	68-23427-26	68-23427-25	68-23427-25	68-23427-25	
Compressor hard start kit	SK-A1	SK-A1	SK-A1	SK-A1	SK-A1	SK-A1	SK-A1	
Low pressure control	RXAC-A07	RXAC-A07	RXAC-A07	RXAC-A07	RXAC-A07	RXAC-A07	RXAC-A07	
High pressure control	RXAB-A07	RXAB-A07	RXAB-A07	RXAB-A07	RXAB-A07	RXAB-A07	RXAB-A07	
Liquid Line Solenoid (24 VAC, 50/60 Hz)	Solenoid Valve	200RD2T3TVLC	200RD2T3TVLC	200RD2T3TVLC	200RD2T3TVLC	200RD2T3TVLC	200RD3T3TVLC	200RD3T3TVLC
	Solenoid Coil	61-AMG24V	61-AMG24V	61-AMG24V	61-AMG24V	61-AMG24V	61-AMG24V	61-AMG24V
Liquid Line Solenoid (120/240 VAC, 50/60 Hz)	Solenoid Valve	200RD2T3TVLC	200RD2T3TVLC	200RD2T3TVLC	200RD2T3TVLC	200RD2T3TVLC	200RD3T3TVLC	200RD3T3TVLC
	Solenoid Coil	61-AMG120/240V	61-AMG120/240V	61-AMG120/240V	61-AMG120/240V	61-AMG120/240V	61-AMG120/240V	61-AMG120/240V

\*Crankcase Heater recommended with Low Ambient Kit.

## Weighted Sound Power Level (dBA)

Unit Size – Voltage, Series	Standard Rating (dBA)	TYPICAL OCTAVE BAND SPECTRUM (dBA without tone adjustment)						
		125	250	500	1000	2000	4000	8000
TZALS1618	76.6	53.4	60.0	65.7	66.3	64.2	58.8	52.6
TZALS1624	75.5	49.9	58.4	61.4	64.1	61.6	57.3	50.8
TZALS1630	74.3	48.4	57.4	62.6	64.5	61.5	56.5	51.5
TZALS1636	76.4	54.5	62.7	67.1	66.5	62.7	58.5	54.3
TZALS1636	75.0	56.1	58.7	63.1	66.1	62.3	59.0	55.7
TZALS1642	70.7	47.5	51.0	60.2	60.7	59.7	53.6	50.4
TZALS1648	74.3	51.2	56.1	64.5	65.6	60.7	56.6	52.6
TZALS1660	74.6	50.1	55.1	65.6	64.8	63.2	57.4	56.4

NOTE: Tested in accordance with AHRI Standard 270-08 (not listed in AHRI).

## Unit Dimensions

MODEL NO.	OPERATING						SHIPPING					
	H (Height)		L (Length)		W (Width)		H (Height)		L (Length)		W (Width)	
	INCHES	mm	INCHES	mm	INCHES	mm	INCHES	mm	INCHES	mm	INCHES	mm
TZALS1618	27	685	29.75	755	29.75	755	30.35	770	33.25	844	33.00	838
TZALS1624	27	685	33.75	857	33.75	857	30.08	764	37.64	956	37.56	954
TZALS1630	27	685	35.75	908	35.75	908	29.68	753	39.37	999	39.64	1006
TZALS1636	31	787	35.75	908	35.75	908	35.15	892	39.37	999	39.64	1006
TZALS1642	39	990	35.75	908	35.75	908	42.00	1066	39.37	999	39.64	1006
TZALS1648	45	1143	35.75	908	35.75	908	48.18	1223	39.37	999	39.64	1006
TZALS1660	51	1295	35.75	908	35.75	908	53.56	1360	39.37	999	39.64	1006

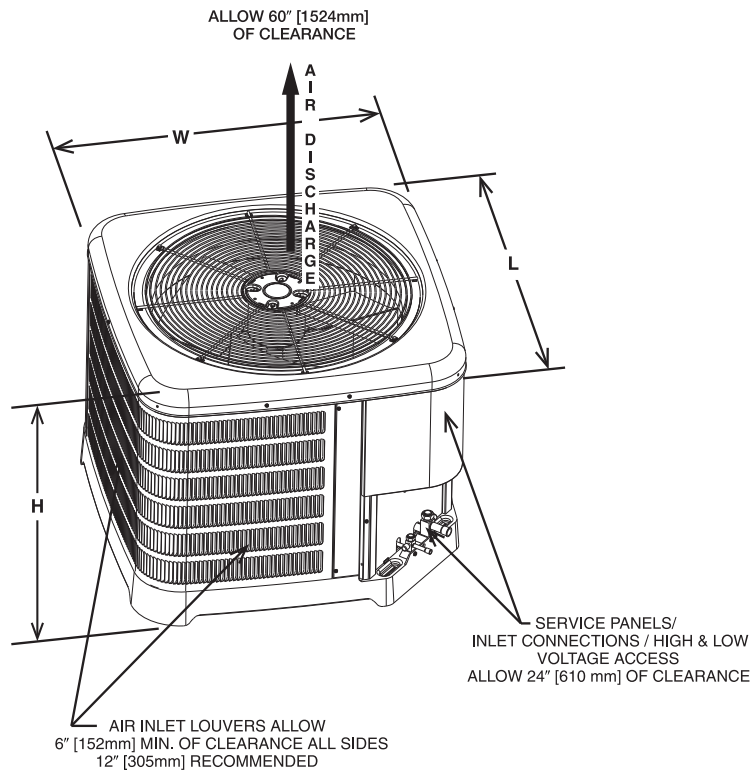

ST-A1226-23-00

[ ] Designates Metric Conversions

# CLEARANCES

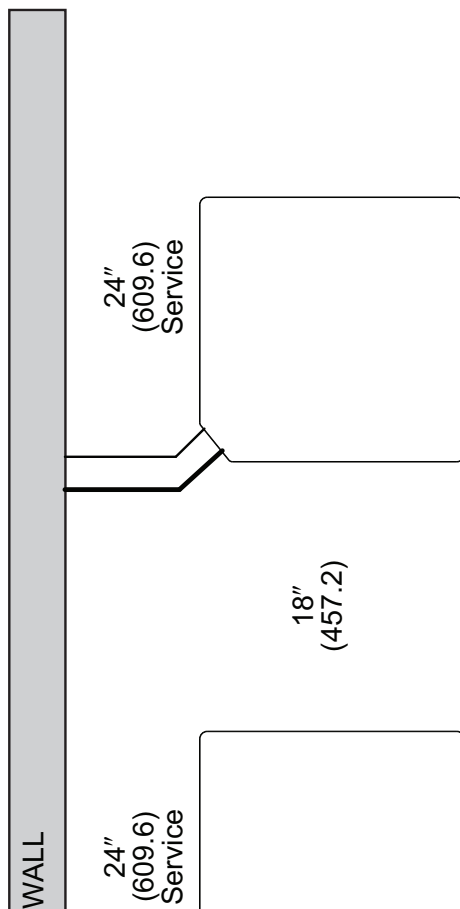
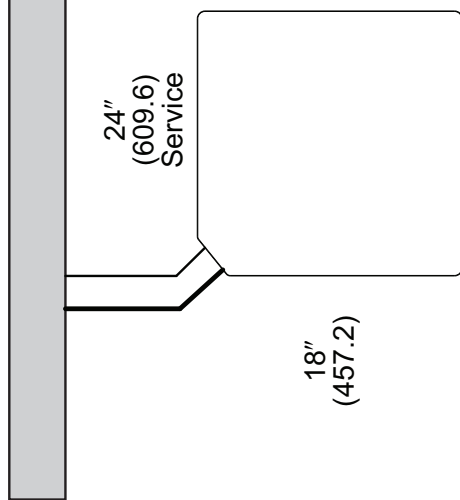
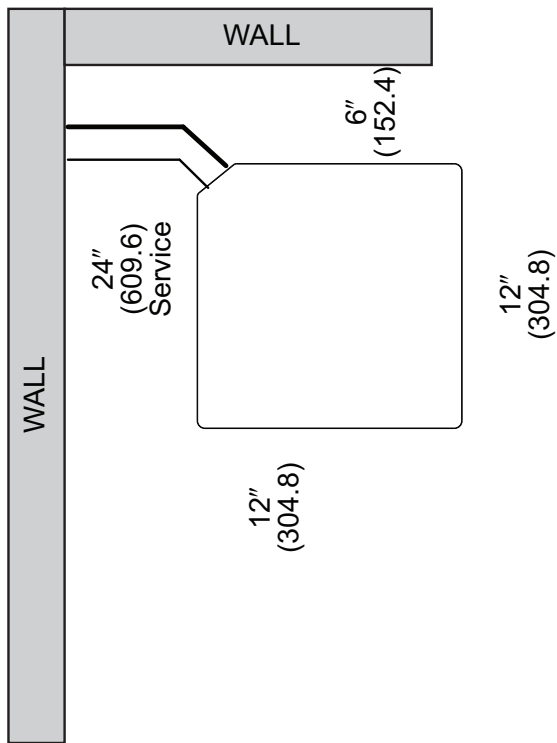
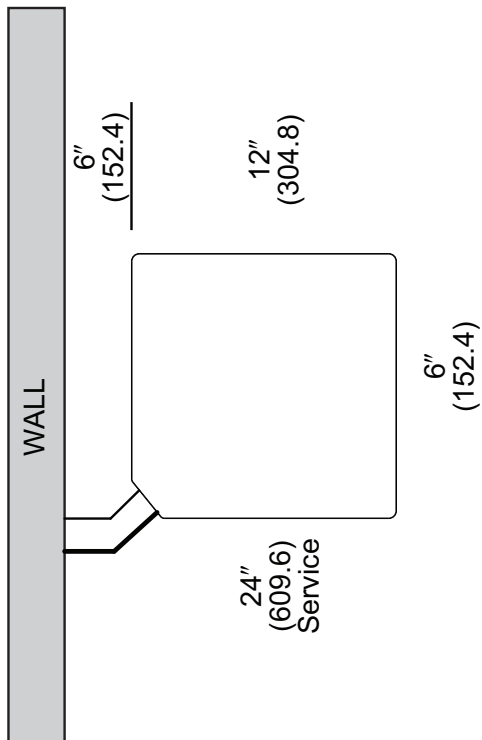

**NOTE: NUMBERS IN ( ) = mm**

IMPORTANT: When installing multiple units in an alcove, roof well or partially enclosed area, ensure there is adequate ventilation to prevent re-circulation of discharge air.

## Control Wiring

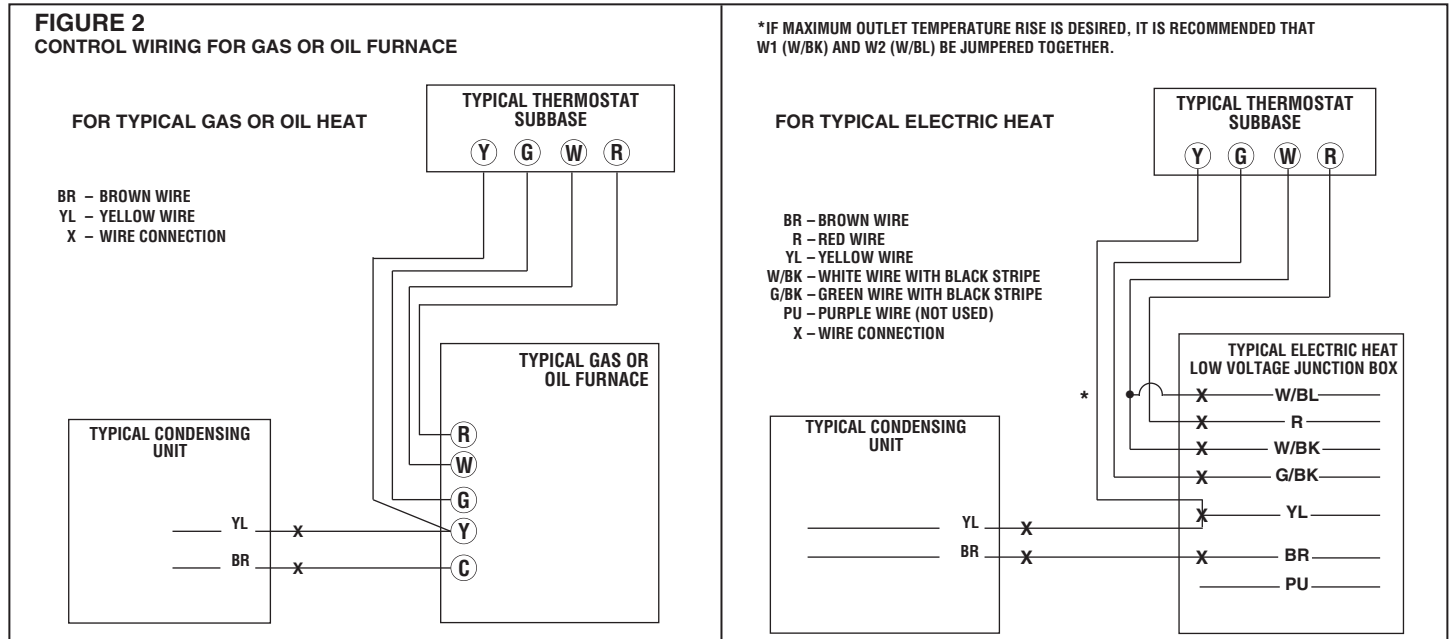

## Application Guidelines

1. Intended for outdoor installation with free air inlet and outlet. Outdoor fan external static pressure available is less than 0.01 -in. wc.
2. Minimum outdoor operation air temperature for cooling mode without low-ambient operation accessory is 55°F (12.8°C).
3. Maximum outdoor operating air temperature is 125°F (51.7°C).
4. For reliable operation, unit should be level in all horizontal planes.
5. For interconnecting refrigerant tube lengths greater than 150 ft. (45.72m) and/or 120 ft. (36.58m) vertical separation, consult Residential Piping and Long line guide.
6. If any refrigerant tubing is buried, provide a 8 in. (203.2mm) vertical rise to the valve connections at the unit. Refrigerant tubing lengths up to 8 ft. (2.44m) may be buried without further consideration. Do not bury refrigerant lines longer than \* in (\* mm)
7. Use only copper wire for electric connections at unit. Aluminum and clad aluminum are not acceptable for the type of connector provided.
8. Do not apply capillary tube indoor coils to these units.
9. Factory - supplied filter drier must be installed.



# Refrigerant Line Size Information

Unit Size	Allowable Liquid Line Size	Allowable Suction Line Size	Apply Long Line Guidelines if Linear Line Length Exceeds Those Shown Below (Feet)						Equivalent Length (Feet)									
			(-)JALS13	(-)JALS14A/B	(-)JALS14W	(-)JALS16	< 25	26-50	51-75	76-100	101-125	126-150	151-175	176-200	201-225	226-250		
			Maximum Vertical Rise (Outdoor Unit Below Indoor Unit) * / Capacity Multiplier															
1.5 Ton **SEE NOTE 3	1/4"	5/8"	N/A	N/A	N/A	N/A	25/1.00	50/0.99	62/0.98	43/0.98	76-100	101-125	126-150	151-175	176-200	201-225	226-250	
	5/16"	5/8"	N/A	223	198	188	25/1.00	50/0.99	75/0.98	98/0.98	93/0.97	88/0.97	83/0.96	78/0.96	73/0.95	68/0.94		
	3/8"	5/8"	178	148	132	125	25/1.00	50/0.99	75/0.98	100/0.98	100/0.97	100/0.97	100/0.96	100/0.96	100/0.95	100/0.94		
	1/4"	3/4"	N/A	N/A	N/A	N/A	25/1.00	50/1.00	62/0.99	43/0.99	24/0.99	24/0.99	5/0.99	N/R	N/R	N/R	N/R	
	5/16"	3/4"	N/A	223	198	188	25/1.00	50/1.00	75/1.00	98/0.99	93/0.99	88/0.99	83/0.99	78/0.98	73/0.98	68/0.98		
	3/8"	3/4"	178	148	132	125	25/1.00	50/1.00	75/1.00	100/0.99	100/0.99	100/0.99	100/0.99	100/0.98	100/0.98	100/0.98		
2 Ton	1/4"	5/8"	N/A	N/A	N/A	N/A	25/0.99	50/0.98	21/0.97	N/R	N/R	N/R	N/R	N/R	N/R	N/R	N/R	
	5/16"	5/8"	243	213	193	175	25/0.99	50/0.98	75/0.97	87/0.96	77/0.95	69/0.94	61/0.93	53/0.92	45/0.91	37/0.90		
	3/8"	5/8"	162	142	128	117	25/0.99	50/0.98	75/0.97	100/0.96	100/0.95	100/0.94	98/0.93	95/0.92	92/0.91	89/0.90		
	1/4"	3/4"	N/A	N/A	N/A	N/A	25/1.00	50/1.00	21/0.99	N/R	N/R	N/R	N/R	N/R	N/R	N/R	N/R	
	5/16"	3/4"	243	213	193	175	25/1.00	50/1.00	75/0.99	87/0.99	77/0.98	69/0.98	61/0.98	53/0.97	45/0.97	37/0.96		
	3/8"	3/4"	162	142	128	117	25/1.00	50/1.00	75/0.99	100/0.99	100/0.98	100/0.98	98/0.98	95/0.97	93/0.97	90/0.96		
2.5 Ton	5/16"	5/8"	N/A	N/A	N/A	N/A	25/0.99	50/0.98	75/0.96	70/0.94	59/0.93	48/0.91	36/0.90	N/R	N/R	N/R	N/R	
	3/8"	5/8"	142	117	88	73	25/0.99	50/0.98	75/0.96	100/0.94	98/0.93	94/0.91	90/0.90	N/R	N/R	N/R	N/R	
	5/16"	3/4"	213	175	133	110	25/1.00	50/0.99	75/0.99	70/0.98	59/0.98	48/0.97	36/0.96	25/0.96	13/0.95	N/R	N/R	
	3/8"	3/4"	142	117	88	73	25/1.00	50/0.99	75/0.99	100/0.98	98/0.98	94/0.97	90/0.96	86/0.96	82/0.95	78/0.95		
	5/16"	5/8"	N/A	N/A	N/A	N/A	25/0.99	50/0.97	66/0.94	49/0.92	32/0.90	N/R	N/R	N/R	N/R	N/R	N/R	
	3/8"	5/8"	108	85	90	82	25/0.99	50/0.97	75/0.94	95/0.92	89/0.90	N/R	N/R	N/R	N/R	N/R	N/R	
3 Ton	5/16"	3/4"	N/A	128	135	123	25/1.00	50/0.99	66/0.98	49/0.92	32/0.97	15/0.96	N/R	N/R	N/R	N/R	N/R	
	3/8"	3/4"	108	85	90	82	25/1.00	50/0.99	75/0.98	95/0.98	89/0.97	84/0.96	78/0.95	72/0.94	67/0.93	61/0.93		
	1/2"	3/4"	54	43	45	41	25/1.00	50/0.99	75/0.98	100/0.98	100/0.97	100/0.96	100/0.95	100/0.94	100/0.93	100/0.93		
	5/16"	7/8"	N/A	128	135	123	25/1.00	50/1.00	66/1.00	49/0.99	32/0.99	15/0.99	N/R	N/R	N/R	N/R	N/R	
	3/8"	7/8"	108	85	90	82	25/1.00	50/1.00	75/1.00	95/0.99	89/0.99	84/0.99	78/0.98	72/0.98	67/0.98	61/0.97		
	1/2"	7/8"	54	43	45	41	25/1.00	50/1.00	75/1.00	100/0.99	100/0.99	100/0.99	100/0.98	100/0.98	100/0.98	100/0.97		
3.5 Ton	3/8"	3/4"	150	123	102	75	25/0.99	50/0.98	75/0.97	88/0.96	80/0.95	72/0.94	65/0.92	57/0.91	49/0.90	N/R	N/R	
	1/2"	3/4"	75	62	51	38	25/0.99	50/0.98	75/0.97	100/0.96	100/0.95	100/0.94	100/0.92	100/0.91	100/0.90	N/R	N/R	
	3/8"	7/8"	150	123	102	75	25/1.00	50/1.00	75/0.99	88/0.99	80/0.99	72/0.98	65/0.97	57/0.97	49/0.96	42/0.96		
	1/2"	7/8"	75	62	51	38	25/1.00	50/1.00	75/0.99	100/0.99	100/0.99	100/0.98	100/0.97	100/0.97	100/0.96	100/0.96		
	3/8"	3/4"	148	110	N/A	35	25/0.99	50/0.98	75/0.96	77/0.95	67/0.93	57/0.92	46/0.91	N/R	N/R	N/R	N/R	
	1/2"	3/4"	74	55	N/A	18	25/0.99	50/0.98	75/0.96	100/0.95	100/0.93	100/0.92	100/0.91	N/R	N/R	N/R	N/R	
4 Ton	3/8"	7/8"	148	110	N/A	35	25/1.00	50/0.99	75/0.99	77/0.98	67/0.97	57/0.97	46/0.96	36/0.96	26/0.95	15/0.95		
	1/2"	7/8"	74	55	N/A	18	25/1.00	50/0.99	75/0.99	100/0.98	100/0.97	100/0.97	100/0.96	100/0.96	99/0.95	97/0.95		
	3/8"	3/4"	78	55	N/A	0	25/0.99	50/0.97	75/0.94	61/0.92	46/0.90	N/R	N/R	N/R	N/R	N/R	N/R	
	1/2"	3/4"	39	28	N/A	0	25/0.99	50/0.97	75/0.94	100/0.92	100/0.90	N/R	N/R	N/R	N/R	N/R	N/R	
	3/8"	7/8"	78	55	N/A	0	25/1.00	50/0.99	75/0.98	61/0.97	46/0.96	32/0.95	18/0.94	N/R	N/R	N/R	N/R	
	1/2"	7/8"	39	28	N/A	0	25/1.00	50/0.99	75/0.98	100/0.97	100/0.96	100/0.96	100/0.95	97/0.94	95/0.94	92/0.93	89/0.92	
5 Ton	3/8"	1-1/8"	78	55	N/A	0	25/1.01	50/1.01	75/1.00	61/1.00	46/0.99	32/0.99	18/0.99	N/R	N/R	N/R	N/R	
	1/2"	1-1/8"	39	28	N/A	0	25/1.01	50/1.01	75/1.00	100/1.00	100/0.99	100/0.99	97/0.99	95/0.99	92/0.99	89/0.98		

**NOTES:**  
 1. Do not exceed 200 ft linear line length.  
 2. \* Do not exceed 100 ft vertical separation if outdoor unit is above indoor unit.  
 3. \*\*3/4" suction line should only be used for 1.5 ton systems if outdoor unit is below or at same level as indoor to assure proper oil return.  
 4. Always use the smallest liquid line allowable to minimize refrigerant charge.  
 5. Applications shaded in light gray indicate capacity multipliers between 0.90 and 0.96 which are not recommended, but are allowed.  
 6. Applications shaded in dark gray are not recommended due to excessive liquid or suction pressure drop.

### Refrigerant Line Size Information (con't.)

Unit Size	Allowable Liquid Line Size mm [in.]	Allowable Suction Line Size mm [in.]	Apply Long Line Guide Lines if Linear Line Length Exceeds Those Shown Below (Meters)		Equivalent Length (Meters)												
			(-)ALS13	(-)ALS14A/B	(-)ALS14W	(-)JALS16	< 8	8-15	16-23	24-30	31-38	39-46	47-53	54-61	62-69	70-76	
			Maximum Vertical Rise (Outdoor Unit Below Indoor Unit) * / Capacity Multiplier														
5.3 KW [1.5 Ton] **SEE NOTE 3	6.35 [1/4]	15.88 [5/8]	N/A	N/A	N/A	8 / 1.00	15 / 0.99	19 / 0.98	13 / 0.98	7 / 0.97	2 / 0.97	N/R	N/R	N/R	N/R	N/R	
	7.94 [5/16]	15.88 [5/8]	N/A	60	57	8 / 1.00	15 / 0.99	23 / 0.98	30 / 0.98	28 / 0.97	27 / 0.97	25 / 0.96	24 / 0.96	22 / 0.95	21 / 0.94		
	9.53 [3/8]	15.88 [5/8]	54	40	38	8 / 1.00	15 / 0.99	23 / 0.98	30 / 0.98	30 / 0.97	30 / 0.97	30 / 0.96	30 / 0.96	30 / 0.95	30 / 0.94		
	6.35 [1/4]	19.05 [3/4]	**	N/A	N/A	8 / 1.00	15 / 1.00	19 / 0.99	13 / 0.99	7 / 0.99	2 / 0.99	N/R	N/R	N/R	N/R	N/R	
	7.94 [5/16]	19.05 [3/4]	**	60	57	8 / 1.00	15 / 1.00	23 / 0.99	30 / 0.99	28 / 0.99	27 / 0.99	25 / 0.99	24 / 0.98	22 / 0.98	21 / 0.98		
7.0 KW [2 Ton]	9.53 [3/8]	19.05 [3/4]	**	54	38	8 / 1.00	15 / 1.00	23 / 0.99	30 / 0.99	30 / 0.99	30 / 0.99	30 / 0.99	30 / 0.98	30 / 0.98	30 / 0.98		
	6.35 [1/4]	15.88 [5/8]	N/A	N/A	N/A	8 / 0.99	15 / 0.98	6 / 0.97	N/R	N/R	N/R	N/R	N/R	N/R	N/R		
	7.94 [5/16]	15.88 [5/8]	74	65	53	8 / 0.99	15 / 0.98	23 / 0.97	27 / 0.96	23 / 0.95	21 / 0.94	19 / 0.93	16 / 0.92	14 / 0.91	11 / 0.90		
	9.53 [3/8]	15.88 [5/8]	49	43	36	8 / 0.99	15 / 0.98	23 / 0.97	30 / 0.96	30 / 0.95	30 / 0.94	30 / 0.93	29 / 0.92	28 / 0.91	27 / 0.90		
	6.35 [1/4]	19.05 [3/4]	N/A	N/A	N/A	8 / 1.00	15 / 1.00	6 / 0.99	N/R	N/R	N/R	N/R	N/R	N/R	N/R		
8.8 KW [2.5 Ton]	7.94 [5/16]	19.05 [3/4]	74	65	53	8 / 1.00	15 / 1.00	23 / 0.99	27 / 0.99	23 / 0.98	21 / 0.98	19 / 0.98	16 / 0.97	14 / 0.97	11 / 0.96		
	9.53 [3/8]	19.05 [3/4]	49	43	39	8 / 1.00	15 / 1.00	23 / 0.99	30 / 0.99	30 / 0.98	30 / 0.98	30 / 0.98	29 / 0.97	28 / 0.97	27 / 0.96		
	6.35 [1/4]	15.88 [5/8]	N/A	N/A	N/A	8 / 0.99	15 / 0.98	23 / 0.96	21 / 0.94	18 / 0.93	15 / 0.91	11 / 0.90	N/R	N/R	N/R		
	7.94 [5/16]	15.88 [5/8]	43	36	27	8 / 0.99	15 / 0.98	23 / 0.96	30 / 0.94	30 / 0.93	29 / 0.91	27 / 0.90	N/R	N/R	N/R		
	9.53 [3/8]	19.05 [3/4]	65	53	40	8 / 1.00	15 / 0.99	23 / 0.99	21 / 0.98	18 / 0.98	15 / 0.97	11 / 0.96	8 / 0.96	4 / 0.95	N/R		
10.6 KW [3 Ton]	9.53 [3/8]	19.05 [3/4]	43	36	27	8 / 1.00	15 / 0.99	23 / 0.99	30 / 0.99	30 / 0.98	29 / 0.97	27 / 0.96	26 / 0.96	25 / 0.95	24 / 0.95		
	7.94 [5/16]	15.88 [5/8]	N/A	N/A	N/A	8 / 0.99	15 / 0.97	20 / 0.94	15 / 0.92	10 / 0.90	N/R	N/R	N/R	N/R	N/R		
	9.53 [3/8]	15.88 [5/8]	33	26	27	8 / 0.99	15 / 0.97	23 / 0.94	29 / 0.92	27 / 0.90	N/R	N/R	N/R	N/R	N/R		
	7.94 [5/16]	19.05 [3/4]	N/A	39	41	37	8 / 1.00	15 / 0.99	20 / 0.98	15 / 0.98	10 / 0.97	5 / 0.96	N/R	N/R	N/R		
	9.53 [3/8]	19.05 [3/4]	33	26	27	8 / 1.00	15 / 0.99	23 / 0.98	29 / 0.98	27 / 0.97	26 / 0.96	24 / 0.95	22 / 0.94	20 / 0.93	19 / 0.93		
12.3 KW [3.5 Ton]	12.70 [1/2]	19.05 [3/4]	17	13	14	8 / 1.00	15 / 0.99	23 / 0.98	30 / 0.98	30 / 0.97	30 / 0.96	30 / 0.95	30 / 0.94	30 / 0.93	30 / 0.93		
	7.94 [5/16]	22.23 [7/8]	N/A	39	41	37	8 / 1.00	15 / 1.00	20 / 1.00	15 / 0.99	10 / 0.99	5 / 0.99	N/R	N/R	N/R		
	9.53 [3/8]	22.23 [7/8]	33	26	27	8 / 1.00	15 / 1.00	23 / 1.00	29 / 0.99	29 / 0.99	27 / 0.99	26 / 0.99	24 / 0.98	22 / 0.98	20 / 0.97		
	12.70 [1/2]	22.23 [7/8]	17	13	14	8 / 1.00	15 / 1.00	23 / 1.00	30 / 0.99	30 / 0.99	30 / 0.99	30 / 0.99	30 / 0.98	30 / 0.98	30 / 0.97		
	9.53 [3/8]	19.05 [3/4]	46	38	31	8 / 0.99	15 / 0.98	23 / 0.97	27 / 0.96	24 / 0.95	22 / 0.94	20 / 0.92	17 / 0.91	15 / 0.90	N/R		
14.1 KW [4 Ton]	12.70 [1/2]	19.05 [3/4]	23	19	15	8 / 0.99	15 / 0.98	23 / 0.97	30 / 0.96	30 / 0.95	30 / 0.94	30 / 0.92	30 / 0.91	30 / 0.90	N/R		
	9.53 [3/8]	22.23 [7/8]	46	38	31	8 / 1.00	15 / 1.00	23 / 0.99	27 / 0.99	27 / 0.99	22 / 0.98	20 / 0.97	17 / 0.97	15 / 0.96	13 / 0.96		
	12.70 [1/2]	22.23 [7/8]	23	19	15	8 / 1.00	15 / 1.00	23 / 0.99	30 / 0.99	30 / 0.99	30 / 0.98	30 / 0.97	30 / 0.97	30 / 0.96	30 / 0.96		
	9.53 [3/8]	19.05 [3/4]	45	34	N/A	8 / 0.99	15 / 0.98	23 / 0.96	24 / 0.95	20 / 0.93	17 / 0.92	14 / 0.91	N/R	N/R	N/R		
	12.70 [1/2]	19.05 [3/4]	23	17	N/A	8 / 0.99	15 / 0.98	23 / 0.96	30 / 0.95	30 / 0.93	30 / 0.92	30 / 0.91	N/R	N/R	N/R		
17.6 KW [5 Ton]	9.53 [3/8]	22.23 [7/8]	45	34	N/A	8 / 1.00	15 / 0.99	23 / 0.99	24 / 0.98	20 / 0.97	17 / 0.97	14 / 0.96	11 / 0.96	8 / 0.95	5 / 0.95		
	12.70 [1/2]	22.23 [7/8]	23	17	N/A	8 / 1.00	15 / 0.99	23 / 0.99	30 / 0.99	30 / 0.98	30 / 0.97	30 / 0.96	30 / 0.96	30 / 0.95	30 / 0.95		
	9.53 [3/8]	19.05 [3/4]	24	17	N/A	8 / 0.99	15 / 0.97	23 / 0.94	19 / 0.92	14 / 0.90	N/R	N/R	N/R	N/R	N/R		
	12.70 [1/2]	19.05 [3/4]	12	8	N/A	8 / 0.99	15 / 0.97	23 / 0.94	30 / 0.92	30 / 0.90	N/R	N/R	N/R	N/R	N/R		
	9.53 [3/8]	22.23 [7/8]	24	17	N/A	8 / 1.00	15 / 0.99	23 / 0.98	19 / 0.97	14 / 0.96	10 / 0.95	5 / 0.94	N/R	N/R	N/R		
17.6 KW [5 Ton]	12.70 [1/2]	22.23 [7/8]	12	8	N/A	8 / 1.00	15 / 0.99	23 / 0.98	30 / 0.97	30 / 0.96	30 / 0.95	30 / 0.94	29 / 0.94	28 / 0.93	27 / 0.92		
	9.53 [3/8]	28.58 [1-1/8]	24	17	N/A	8 / 1.01	15 / 1.01	23 / 1.00	19 / 1.00	14 / 0.99	10 / 0.99	5 / 0.99	N/R	N/R	N/R		
	12.70 [1/2]	28.58 [1-1/8]	12	8	N/A	8 / 1.01	15 / 1.01	23 / 1.00	30 / 1.00	30 / 1.00	30 / 0.99	30 / 0.99	29 / 0.99	28 / 0.99	27 / 0.98		

- NOTES:**
- Do not exceed 61 meters linear line length.
  - Do not exceed 30 meters vertical separation if outdoor unit is above indoor unit.
  - \*\*19.05 mm [3/4 in.] suction line should only be used for 1.5 ton systems if outdoor unit is below or at same level as indoor to assure proper oil return.
  - Always use the smallest liquid line allowable to minimize refrigerant charge.
  - Applications shaded in light gray indicate capacity multipliers between 0.90 and 0.96 which are not recommended, but are allowed.
  - Applications shaded in dark gray are not recommended due to excessive liquid or suction pressure drop.

## Performance Data @ AHRI Standard Conditions – Cooling

Designated Tested Combination (DTC)							
Outdoor Unit	Indoor Coil	Total Capacity BTU/H [kW]	Net Sensible BTU/H [kW]	Net Latent BTU/H [kW]	SEER	EER	Indoor CFM [L/s]
TZALS16182	TCF2417STA	18000 [5.3]	13500 [4.0]	4500 [1.3]	14.50	12.20	600 [283.2]
TZALS16242	TCF2417STA	24000 [7.0]	17500 [5.1]	6500 [1.9]	14.50	12.20	800 [377.6]
TZALS16302	TCF3617STA	28400 [8.3]	21600 [6.3]	6800 [2.0]	14.50	12.20	1025 [483.7]
TZALS16362	TCF3617STA	34800 [10.2]	24700 [7.2]	10100 [3.0]	14.50	12.20	1000 [471.9]
TZALS16422	TCF4821STA	41000 [12.0]	30400 [8.9]	10600 [3.1]	14.50	12.20	1425 [672.5]
TZALS16482	TCF4821MTA	46000 [13.5]	33200 [9.7]	12800 [3.8]	15.00	12.50	1600 [755.1]
TZALS16602	TCF6024STA	56500 [16.6]	41200 [12.1]	15300 [4.5]	15.00	12.50	1525 [719.7]

Air Handler							
Outdoor Unit	Indoor Coil	Total Capacity BTU/H [kW]	Net Sensible BTU/H [kW]	Net Latent BTU/H [kW]	SEER	EER	Indoor CFM [L/s]
TZALS16182	TZHSLTST2417	18000 [5.3]	13500 [4.0]	4500 [1.3]	16.00	13.00	600 [283.2]
TZALS16242	TZHSLTST2417	24000 [7.0]	17500 [5.1]	6500 [1.9]	16.00	13.00	800 [377.6]
TZALS16302	TZHSLTST3617	29000 [8.5]	21600 [6.3]	6800 [2.0]	16.00	13.00	1000 [471.9]
TZALS16362	TZHSLTST3617	35400 [10.3]	24700 [7.2]	10100 [3.0]	16.00	13.00	1000 [471.9]
TZALS16422	TZHSLTST4821	41500 [12.2]	33200 [9.7]	12800 [3.8]	16.00	13.00	1400 [660.7]
TZALS16482	TZHSLTST4821	42000 [12.2]	41200 [12.1]	15300 [4.5]	16.00	13.00	1400 [660.7]
TZALS16602	TZHSLTST6021	56000 [16.4]	41200 [12.1]	15300 [4.5]	15.50	12.50	1575 [755.2]

**Note:** Additional ratings and system match ups and downloadable ratings certificates can be accessed from the AHRI website: [www.ahrirectory.org](http://www.ahrirectory.org)

[ ] Designates Metric Conversions

## GUIDE SPECIFICATIONS

### General

#### System Description

Outdoor-mounted, air-cooled, split-system air conditioner composite base pan unit suitable for ground or rooftop installation. Unit consists of a hermetic compressor, an air-cooled coil, propeller-type condenser fan, suction and legend line service valve, and a control box. Unit will discharge supply air upward as shown on contract drawings. Unit will be used in a refrigeration circuit to match up to a coil unit.

#### Quality Assurance

- Unit will be rated in accordance with the latest edition of AHRI Standard 210.
- Unit will be certified for capacity and efficiency, and listed in the latest AHRI directory.
- Unit construction will comply with latest edition of ANSI/ASHRAE and with NEC.
- Unit will be constructed in accordance with UL standards and will carry the UL label of approval. Unit will have c-UL-us approval.
- Unit cabinet will be capable of withstanding ASTM B117 1000-hr salt spray test.
- Air-cooled condenser coils will be leak tested at 150 psig and pressure tested at 550 psig.
- Unit constructed in ISO9001 approved facility.

#### Delivery, Storage, and Handling

- Unit will be shipped as single package only and is stored and handled per unit manufacturer's recommendations.

**Warranty (for inclusion by specifying engineer)** — U.S. and Canada only.

### Products

#### Equipment

Factory assembled, single piece, air-cooled air conditioner unit. Contained within the unit enclosure is all factory wiring, piping, controls, compressor, refrigerant charge R-410A, and special features required prior to field start-up.

#### Unit Cabinet

- Unit cabinet will be constructed of galvanized steel, bonderized, and coated with a powder coat paint.
- All units constructed with louver coil protection and corner post. Louver can be removed by removing one fastener per louver panel.

### AIR-COOLED, SPLIT-SYSTEM AIR CONDITIONER

#### TZALS-16

#### 1-1/2 TO 5 NOMINAL TONS

#### Fans

- Condenser fan will be direct-drive propeller type, discharging air upward.
- Condenser fan motors will be totally enclosed, 1-phase type with class B insulation and permanently lubricated bearings. Shafts will be corrosion resistant.
- Fan blades will be statically and dynamically balanced.
- Condenser fan openings will be equipped with coated steel wire safety guards.

#### Compressor

- Compressor will be hermetically sealed.
- Compressor will be mounted on rubber vibration isolators.

#### Condenser Coil

- Condenser coil will be air cooled.
- Coil will be constructed of aluminum fins mechanically bonded to copper tubes.

#### Refrigeration Components

- Refrigeration circuit components will include liquid-line shutoff valve with sweat connections, vapor-line shutoff valve with sweat connections, system charge of R-410A refrigerant, and compressor oil.
- Unit will be equipped with filter drier for R-410A refrigerant for field installation.

#### Operating Characteristics

- The capacity of the unit will meet or exceed \_\_\_\_\_ Btuh at a suction temperature of \_\_\_\_\_ °F/°C. The power consumption at full load will not exceed \_\_\_\_\_ kW.
- Combination of the unit and the evaporator or fan coil unit will have a total net cooling capacity of \_\_\_\_\_ Btuh or greater at conditions of \_\_\_\_\_ CFM entering air temperature at the evaporator at \_\_\_\_\_ °F/°C wet bulb and \_\_\_\_\_ °F/°C dry bulb, and air entering the unit at \_\_\_\_\_ °F/°C.
- The system will have a SEER of \_\_\_\_\_ Btuh/watt or greater at DOE conditions.

#### Electrical Requirements

- Nominal unit electrical characteristics will be \_\_\_\_\_ v, single phase, 60 hz. The unit will be capable of satisfactory operation within voltage limits of \_\_\_\_\_ v to \_\_\_\_\_ v.
- Nominal unit electrical characteristics will be \_\_\_\_\_ v, three phase, 60 hz. The unit will be capable of satisfactory operation within voltage limits of \_\_\_\_\_ v to \_\_\_\_\_ v.
- Unit electrical power will be single point connection.
- Control circuit will be 24v.

#### Special Features

- Refer to section of this literature identifying accessories and descriptions for specific features and available enhancements.

**GENERAL TERMS OF LIMITED WARRANTY\***

Thermal Zone will furnish a replacement for any part of this product which fails in normal use and service within the applicable period stated, in accordance with the terms of the limited warranty.

**\*For complete details of the Limited and Conditional Warranties, including applicable terms and conditions, contact your local contractor or the Manufacturer for a copy of the product warranty certificate.**

Conditional Parts  
(Registration Required) .....Ten (10) Years





---

**Before proceeding with installation, refer to installation instructions packaged with each model, as well as complying with all Federal, State, Provincial, and Local codes, regulations, and practices.**

---

*"In keeping with its policy of continuous progress and product improvement, the right is reserved to make changes without notice."*